

May 2009

# EZ1<sup>®</sup> Advanced XL User Manual

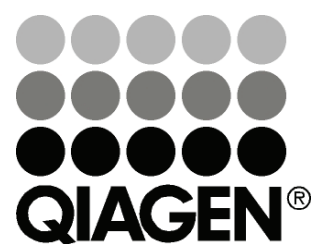

Sample & Assay Technologies

Trademarks: QIAGEN®, EZ1® (QIAGEN Group); DECON-QUAT® (Veltek Associates, Inc.); Gigasept®, Lysetol®, Mikroqid® (Schülke & Mayr GmbH); IBM® (International Business Machines Corporation); Microsoft®, Windows® (Microsoft Corporation).

© 2009 QIAGEN, all rights reserved.

# Contents

<b>1</b>	<b>Safety Information</b>	<b>1-1</b>
1.1	Proper use	1-2
1.2	Electrical safety	1-3
1.3	Environment	1-4
1.4	Biological safety	1-4
1.5	Chemicals	1-6
1.6	Waste disposal	1-6
1.7	Mechanical hazards	1-7
1.8	Heat hazard	1-7
1.9	UV radiation	1-7
1.10	Symbols on the EZ1 Advanced XL	1-8
1.11	Additional symbols in this user manual	1-9
<b>2</b>	<b>Introduction</b>	<b>2-1</b>
2.1	About this user manual	2-1
2.2	General information	2-1
2.2.1	Technical assistance	2-1
2.2.2	Policy statement	2-2
2.2.3	Version management	2-2
2.3	Intended use of the EZ1 Advanced XL	2-2
2.3.1	Requirements for EZ1 Advanced XL users	2-3
<b>3</b>	<b>General Description</b>	<b>3-1</b>
3.1	External features of the EZ1 Advanced XL	3-2
3.1.1	EZ1 Advanced XL door	3-2
3.1.2	Control panel	3-2
3.1.3	EZ1 Advanced XL Card slot	3-4
3.1.4	Status LEDs	3-5

## Contents

---

3.1.5	Connector panel	3-5
3.2	Internal features of the EZ1 Advanced XL	3-6
3.2.1	Worktable	3-6
3.2.2	Pipettor head	3-11
3.2.3	UV lamp	3-12
<b>4</b>	<b>Installation Procedures</b>	<b>4-1</b>
4.1	Requirements	4-1
4.2	AC power connection	4-1
4.3	Hardware installation	4-3
4.3.1	Unpacking the EZ1 Advanced XL	4-4
4.3.2	Installing the EZ1 Advanced XL	4-8
4.3.3	Configuring and setting up the EZ1 Advanced XL	4-9
4.3.4	Installing the printer (optional)	4-10
4.3.5	Installing the bar code reader	4-10
4.4	Installing the PC software	4-11
4.4.1	System requirements	4-12
4.4.2	Installing the driver of the USB-RS232 converter	4-12
4.4.3	Installing the EZ1 Advanced Communicator software	4-16
4.5	Installing multiple EZ1 Advanced XL instruments	4-16
4.6	Transportation and removal of the EZ1 Advanced XL	4-20
<b>5</b>	<b>General Operation</b>	<b>5-1</b>
5.1	Overview	5-1
5.2	Inserting and removing the EZ1 Advanced XL Card	5-2
5.2.1	Inserting the EZ1 Advanced XL Card	5-2
5.2.2	Removing the EZ1 Advanced XL Card	5-4
5.3	Switching the EZ1 Advanced XL on and off	5-5
5.3.1	Switching on the EZ1 Advanced XL	5-5
5.3.2	Switching off the EZ1 Advanced XL	5-6
5.4	Opening and closing the EZ1 Advanced XL door	5-7

5.4.1	Opening the EZ1 Advanced XL door	5-7
5.4.2	Closing the EZ1 Advanced XL door	5-7
5.5	Starting and stopping a protocol run	5-8
5.5.1	Starting and finishing a protocol run	5-8
5.5.2	Stopping a protocol run	5-9
5.6	Setting up the worktable	5-10
5.6.1	Removing and replacing the tray	5-11
5.6.2	Loading the reagent cartridges	5-11
5.6.3	Loading the elution tubes, filter-tips, and sample tubes	5-13
5.7	Using the UV lamp	5-15
5.7.1	Switching on the UV lamp	5-16
5.7.2	Switching off the UV lamps	5-17
5.7.3	Lifetime reminder of the UV lamps	5-18
5.7.4	UV lamps ignition error	5-18
5.8	Manual operation	5-19
5.8.1	Manual operation "home axis"	5-19
5.8.2	Manual operation "return tip"	5-20
5.8.3	Manual operation "clean"	5-20
5.8.4	Manual operation "resend"	5-21
5.9	Test	5-22
5.9.1	Test axis	5-23
5.9.2	Test heating block	5-24
5.9.3	Test serial port	5-25
5.9.4	Test version	5-28
5.10	System setup	5-28
5.10.1	Setting the date	5-28
5.10.2	Setting the time	5-29
5.10.3	Setting the serial port	5-30
5.10.4	Setting the preventive maintenance reminder	5-31
5.11	Using the bar code reader	5-31
5.12	Using the external printer (optional)	5-32

## Contents

---

5.13	Generating a report file	5-34
5.14	Using the EZ1 Advanced Communicator software	5-38
5.14.1	User interface	5-38
5.14.2	Report file in pdf format	5-41
5.15	Using multiple EZ1 Advanced XL instruments	5-42
5.16	Evaluating pipetting accuracy	5-42
<b>6</b>	<b>Preventive Maintenance</b>	<b>6-1</b>
6.1	Regular maintenance procedure	6-3
6.2	Daily maintenance procedure	6-6
6.3	Weekly maintenance procedure	6-8
6.4	Reagents for decontamination	6-9
<b>7</b>	<b>Troubleshooting</b>	<b>7-1</b>
7.1	Detecting an error	7-1
7.1.1	EZ1 Advanced XL door errors	7-1
7.1.2	Other errors	7-1
7.2	Error codes	7-3
<b>8</b>	<b>Glossary</b>	<b>8-1</b>
	<b>Appendix A</b>	<b>A-1</b>
	Technical data	A-1
	Environmental conditions	A-1
	Waste Electrical and Electronic Equipment (WEEE)	A-6
	FCC declaration	A-7
	EC declaration of conformity	A-8
	<b>Appendix B</b>	<b>B-1</b>
	Liability clause	B-1

**Index**

**Index-1**

## Contents

---

This page intentionally left blank





# 1 Safety Information

This manual contains information and warnings that must be followed by the user to ensure safe operation of the EZ1 Advanced XL and to maintain the instrument in a safe condition.

Possible hazards that could harm the user or result in damage to the instrument are clearly stated at the appropriate places throughout this manual.

If the equipment is used in a manner not specified by the manufacturer, the protection provided by the equipment may be impaired.

The following safety conventions are used throughout this manual.

<p><b>WARNING</b></p> 	<p>The term <b>WARNING</b> is used to inform you about situations that could result in <b>personal injury</b> to you or other persons. Details about these circumstances are given in a box like this one.</p>
<p><b>CAUTION</b></p> 	<p>The term <b>CAUTION</b> is used to inform you about situations that could result in <b>damage to the instrument</b> or other equipment. Details about these circumstances are given in a box like this one.</p>

Before using the instrument, it is essential to read this manual carefully and to pay particular attention to any advice it contains concerning hazards that may arise from use of the instrument.

The advice given in this manual is intended to supplement, not supersede, the normal safety requirements prevailing in the user's country.

## 1.1 Proper use

<b>WARNING</b>	<b>Risk of personal injury and material damage</b> [W1]
	Improper use of the EZ1 Advanced XL may cause personal injuries or damage to the instrument. The EZ1 Advanced XL must only be operated by qualified personnel who have been appropriately trained. Servicing of the EZ1 Advanced XL must only be performed by QIAGEN Instrument Service Specialists.

Use only QIAGEN® components, otherwise your right to make a claim under the guarantee may be invalidated. Carry out the maintenance regularly in accordance with the operating instructions. QIAGEN charges for repairs that prove to be required due to incorrect maintenance.

<b>WARNING</b>	<b>Risk of personal injury</b> [W2]
	Two people must carry the instrument. Use the handle attached to the box to lift the EZ1 Advanced XL. After the EZ1 Advanced XL has been unpacked, 2 people must lift the instrument. Lift the instrument by placing your hands underneath the bottom of the instrument.

In case of an emergency or malfunction, switch off the EZ1 Advanced XL at the power switch at the rear of the instrument and unplug the power cord from the wall power outlet. Contact the address stated on the back cover of the *EZ1 Advanced XL User Manual*.

<b>WARNING</b>	<b>Explosive atmosphere</b> [W3]
	The EZ1 Advanced XL is not designed for use in an explosive atmosphere. The EZ1 Advanced XL is intended for use with reagents and substances supplied with QIAGEN kits. Use of other reagents and substances may lead to fire or explosion.

<p><b>CAUTION</b></p> 	<p><b>Damage to the instrument</b> <span style="float: right;">[C1]</span></p> <p>Avoid spilling water or chemicals onto the EZ1 Advanced XL. Instrument damage caused by water or chemical spillage will void your warranty.</p>
---	---

<p><b>CAUTION</b></p> 	<p><b>Damage to the instrument</b> <span style="float: right;">[C2]</span></p> <p>Ensure that the EZ1 Advanced XL is switched off before you manually move the mechanical components of the instrument.</p>
---	---

## 1.2 Electrical safety

To ensure satisfactory and safe operation of the EZ1 Advanced XL, it is essential that the line power cord is connected to true electrical earth (ground).

<p><b>WARNING</b></p> 	<p><b>Electrical hazard</b> <span style="float: right;">[W4]</span></p> <p>Any interruption of the protective conductor (earth/ground lead) inside or outside the instrument or disconnection of the protective conductor terminal is likely to make the instrument dangerous. Intentional interruption is prohibited.</p> <p><b>Lethal voltages inside the instrument</b></p> <p>When the instrument is connected to line power, terminals may be live, and opening covers or removing parts is likely to expose live parts.</p>
---	---

When working with the EZ1 Advanced XL:

- Make sure that the line power cord is connected to a line power outlet that has a protective conductor (earth/ground).
- Do not attempt to make any internal adjustments or replacements.
- Do not operate the instrument with any covers or parts removed.
- If water or reagent has spilled inside the instrument, switch off the instrument and disconnect it from the line power supply. Call QIAGEN Technical Services.
- Servicing should be carried out only by QIAGEN Instrument Service Specialists.

## Safety Information

---

- If the instrument becomes electrically unsafe for use, make the instrument inoperative and secure it against unauthorized or unintentional operation. Call QIAGEN Technical Services.

The instrument is likely to be electrically unsafe when:

- It shows visible damage
- The line power cord shows signs of damage
- It has been stored under unfavorable conditions for a prolonged period
- It has been subjected to severe transport stresses

If water, reagent, sample, or ethanol has spilled onto or into the instrument, switch off the instrument and disconnect it from the line power supply. Call QIAGEN Technical Services.

<b>WARNING</b> 	<b>Risk of electric shock</b> [W5] Do not touch the EZ1 Advanced XL with wet hands.
--	--

## 1.3 Environment

### Operating conditions

<b>WARNING</b> 	<b>Explosive atmosphere</b> [W6] The EZ1 Advanced XL is not designed for use in an explosive atmosphere.
---	---

## 1.4 Biological safety

Specimens and reagents containing materials from humans should be treated as potentially infectious. Use safe laboratory procedures as outlined in publications such as *Biosafety in Microbiological and Biomedical Laboratories*, HHS ([www.cdc.gov/od/ohs/biosfty/biosfty.htm](http://www.cdc.gov/od/ohs/biosfty/biosfty.htm)).

## Samples

Samples may contain infectious agents. You should be aware of the health hazard presented by such agents and should use, store, and dispose of such samples in accordance with the required safety regulations.

<p><b>WARNING</b></p> 	<p><b>Samples containing infectious agents</b> [W7]</p> <p>Some samples used with this instrument may contain infectious agents. Handle such samples with the greatest of care and in accordance with the required safety regulations.</p> <p>Always wear safety glasses, 2 pairs of gloves, and a lab coat.</p> <p>The responsible body (e.g., laboratory manager) must take the necessary precautions to ensure that the surrounding workplace is safe, and that the instrument operators are suitably trained and not exposed to hazardous levels of infectious agents as defined in the applicable Material Safety Data Sheets (MSDSs) or OSHA, ACGIH, or COSHH documents.</p> <p>Venting for fumes and disposal of wastes must be in accordance with all national, state, and local health and safety regulations and laws.</p>
---	--

OSHA: Occupational Safety and Health Administration (United States of America).

ACGIH: American Conference of Government Industrial Hygienists (United States of America).

COSHH: Control of Substances Hazardous to Health (United Kingdom).

## 1.5 Chemicals

<b>WARNING</b>	<b>Hazardous chemicals</b> <span style="float: right;">[W8]</span>
	<p>Some chemicals used with this instrument may be hazardous or may become hazardous after completion of the protocol run.</p> <p>Always wear safety glasses, gloves, and a lab coat. The responsible body (e.g., laboratory manager) must take the necessary precautions to ensure that the surrounding workplace is safe and that the instrument operators are not exposed to hazardous levels of toxic substances (chemical or biological) as defined in the applicable Material Safety Data Sheets (MSDSs) or OSHA, ACGIH, or COSHH documents.</p> <p>Venting for fumes and disposal of wastes must be in accordance with all national, state, and local health and safety regulations and laws.</p>

OSHA: Occupational Safety and Health Administration (United States of America).

ACGIH: American Conference of Government Industrial Hygienists (United States of America).

COSHH: Control of Substances Hazardous to Health (United Kingdom).

### Toxic fumes

If you work with volatile solvents, toxic substances, etc., you must provide an efficient laboratory ventilation system to remove vapors that may be produced.

## 1.6 Waste disposal

Used labware, such as reagent cartridges and filter-tips, may contain hazardous chemicals or infectious agents from the purification process. Such wastes must be collected and disposed of properly in accordance with the local safety regulations.

For disposal of waste electrical and electronic equipment (WEEE), see page A-6.

## 1.7 Mechanical hazards

The worktable of the EZ1 Advanced XL moves during operation of the instrument.

<p><b>WARNING</b></p> 	<p><b>Moving parts</b> <span style="float: right;">[W9]</span></p> <p>Never open the EZ1 Advanced XL door while the EZ1 Advanced XL is operating.</p>
---	---

<p><b>WARNING</b></p> 	<p><b>Risk of overheating</b> <span style="float: right;">[W10]</span></p> <p>To ensure proper ventilation, maintain a minimum clearance of 15 cm and 30 cm at the rear and sides of the EZ1 Advanced XL, respectively. Slits and openings that ensure the ventilation of the EZ1 Advanced XL must not be covered.</p>
---	--

## 1.8 Heat hazard

The EZ1 Advanced XL worktable contains a heating system.

<p><b>WARNING</b></p> 	<p><b>Hot surface</b> <span style="float: right;">[W11]</span></p> <p>The heating system can reach high temperatures. Avoid touching it when it is hot.</p>
---	---

## 1.9 UV radiation





<p><b>WARNING</b></p> 	<p><b>The EZ1 Advanced XL contains 2 UV lamps</b> <span style="float: right;">[W12]</span></p> <p>Avoid looking directly into UV light. Do not expose your skin to UV light.</p>
---	--

The wavelength of the UV light produced by the UV lamp is 253.7 nm. This wavelength corresponds to ultraviolet light type C, which can be used for decontamination procedures.





## Safety Information

<p><b>WARNING</b></p> 	<p><b>UV lamp</b> <span style="float: right;">[W13]</span></p> <p>The UV lamp consists of a robust glass cylinder. It is safely located inside the door of the EZ1 Advanced XL. In case of accidental breakage of the lamp, contact QIAGEN Technical Services or your local distributor to arrange proper disposal of the lamp.</p>
---	---

### 1.10 Symbols on the EZ1 Advanced XL

Symbol	Location	Description
	Heating system	Heat hazard — the temperature of the heating system can reach up to 95°C
	Near the tip rack	Biohazard — the tip rack may be contaminated with biohazardous material and must be handled with gloves
	On the back of the instrument	UV radiation hazard. UV light could burn your skin and cause damage to your eye
	Near the pipettor head	Crush hazard — the nozzle unit may crush your fingers or hand
	Near the tip rack	UV lamp heat hazard — the UV lamp is hot. Do not touch the UV lamp



Symbol	Location	Description
	Type plate on the back of the instrument	CE mark for Europe
	Type plate on the back of the instrument	UL listing mark for Canada and the USA
	Type plate on the back of the instrument	RoHS mark for China (the restriction of the use of certain hazardous substances in electrical and electronic equipment)
	Type plate on the back of the instrument	WEEE mark for Europe
<b>SN</b>	Type plate on the back of the instrument	Serial number
	Type plate on the back of the instrument	Legal manufacturer

### 1.11 Additional symbols in this user manual

Symbol	Location	Description
	Front cover	Catalog number

## Safety Information

---

Symbol	Location	Description
	Front cover	Handbook

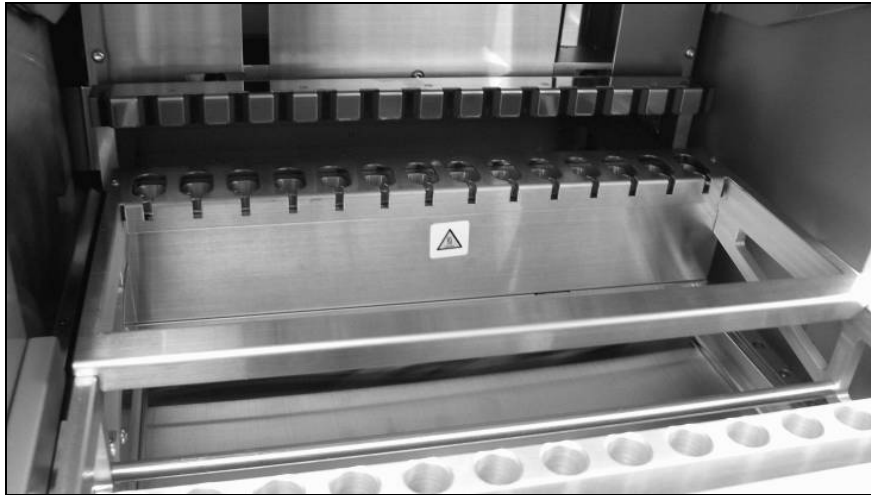

**Symbol on the heating system.**



**Symbol near the tip rack.**

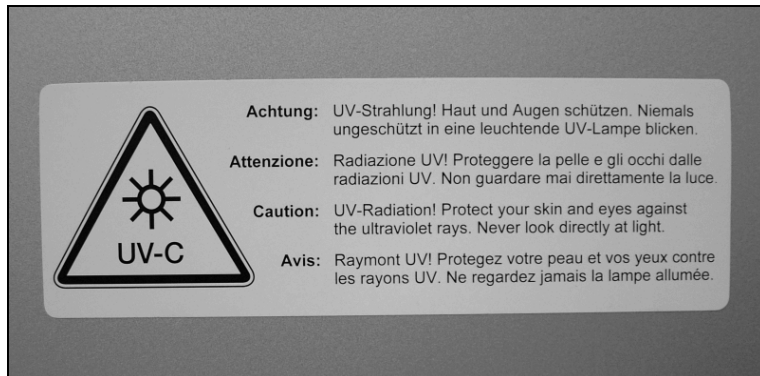

**Symbol on back of the EZ1 Advanced XL.**

## Safety Information

---

This page intentionally left blank

## **2 Introduction**

Thank you for choosing the QIAGEN EZ1 Advanced XL. We are confident it will become an integral part of your laboratory.

Before using the instrument, it is essential to read this manual carefully and to pay particular attention to any advice it contains concerning hazards that may arise from use of this instrument.

### **2.1 About this user manual**

This manual provides information about the EZ1 Advanced XL. It guides you systematically through the following sections:

1. Safety Information
2. Introduction
3. General Description
4. Installation Procedures
5. General Operation
6. Preventive Maintenance
7. Troubleshooting
8. Glossary

Appendices

The Appendices contain the following:

- Technical data
- Liability clause

### **2.2 General information**

#### **2.2.1 Technical assistance**

At QIAGEN we pride ourselves on the quality and availability of our technical support. Our Technical Service Departments are staffed by experienced scientists with extensive practical and theoretical expertise in molecular biology and the use of QIAGEN products. If you have any questions regarding the

EZ1 Advanced XL or QIAGEN products in general, please do not hesitate to contact us.

QIAGEN customers are a major source of information regarding advanced or specialized uses of our products. This information is helpful to other scientists as well as to the researchers at QIAGEN. We therefore encourage you to contact us if you have any suggestions about product performance or new applications and techniques.

For technical assistance and more information, please see our Technical Support Center at [www.qiagen.com/Support](http://www.qiagen.com/Support) or call one of the QIAGEN Technical Service Departments or local distributors (see back cover or visit [www.qiagen.com](http://www.qiagen.com)).

### **2.2.2 Policy statement**

It is the policy of QIAGEN to improve products as new techniques and components become available. QIAGEN reserves the right to change specifications at any time.

In an effort to produce useful and appropriate documentation, we appreciate your comments on this publication. Please contact QIAGEN Technical Services.

### **2.2.3 Version management**

This document is the *EZ1 Advanced XL User Manual*, revision R1.

## **2.3 Intended use of the EZ1 Advanced XL**

The EZ1 Advanced XL is designed to perform automated isolation and purification of nucleic acids.

It is intended to be used only in combination with QIAGEN kits indicated for use with the EZ1 Advanced XL instrument for the applications described in the kit handbooks.

The system is intended for use by professional users, such as technicians and physicians trained in molecular biological techniques and the operation of the EZ1 Advanced XL.

### 2.3.1 Requirements for EZ1 Advanced XL users

This table covers the general level of competence and training necessary for transportation, installation, use, maintenance, and servicing of the EZ1 Advanced XL.

Type of task	Personnel	Training and experience
Transportation	No special requirements	No special requirements
Installation	Laboratory technicians or equivalent	Appropriately trained and experienced personnel familiar with use of computers and automation in general
Routine use (running protocols)	Laboratory technicians or equivalent	Appropriately trained and experienced personnel familiar with use of computers and automation in general
Regular, daily, and weekly maintenance	Laboratory technicians or equivalent	Appropriately trained and experienced personnel familiar with use of computers and automation in general
Servicing and annual preventive maintenance	<b>QIAGEN Instrument Service Specialists only</b>	

## Introduction

---

This page intentionally left blank



### **3 General Description**

The EZ1 Advanced XL performs fully automated nucleic acid purification from up to 14 samples using magnetic particles. The automated steps include:

- Reading reagent and sample information with a handheld bar code scanner connected to the EZ1 Advanced XL
- Lysis of samples
- Binding of nucleic acids to magnetic particles
- Washing and elution of nucleic acids
- Generating a report file that either will be transmitted to a PC or printed on an external printer after the protocol run is finished
- Using UV radiation for decontamination

The user inserts an EZ1 Advanced XL Card containing protocol(s) into the EZ1 Advanced XL. After starting worktable setup using the control panel and bar code reader, the user loads samples, reagent cartridges, filter-tips in tip holders, and elution tubes onto the EZ1 Advanced XL worktable.

The user then closes the EZ1 Advanced XL door and starts the protocol. The door locks automatically at the start of the protocol. The protocol provides the necessary instructions for the EZ1 Advanced XL to carry out automated nucleic acid purification.

The aspiration and dispensing of samples and reagents and the separation of magnetic particles are performed by the 14-channel pipettor head. The temperature of samples is regulated by a heating system.

### 3.1 External features of the EZ1 Advanced XL



**Front view of the EZ1 Advanced XL.**

- |                               |                                    |
|-------------------------------|------------------------------------|
| <b>1</b> EZ1 Advanced XL door | <b>3</b> EZ1 Advanced XL Card slot |
| <b>2</b> Control panel        | <b>4</b> Status LEDs               |

#### 3.1.1 EZ1 Advanced XL door

The EZ1 Advanced XL door can be manually opened by the user in order to gain access to the worktable when no protocol is running. A protocol cannot be started until the EZ1 Advanced XL door is closed.

#### 3.1.2 Control panel

The control panel is the user interface that allows the user to operate the EZ1 Advanced XL. It consists of a keypad and a vacuum fluorescent display (VFD).

## Keypad

The following keys of the control panel are available to the user.

Key	Description
0–9	Selects a menu or specifies process parameters (e.g., sample volume).
START	Initiates an action or starts a protocol.
STOP	Interrupts a protocol run.
ESC	Displays the previous menu or text.
Up/Dn	Up and down arrow key used, for example, in the system setup menu.
ENT	Enter key used, for example, in the system setup menu to acknowledge data entry.
BS	Backspace key used to remove incorrectly entered values during data entry.
SHIFT + Up/Dn	Used to enter the installation date.

The other keys of the control panel are for service personnel only.

## Vacuum fluorescent display (VFD)

The display consists of 4 lines with 20 characters per line.

## General Description

---

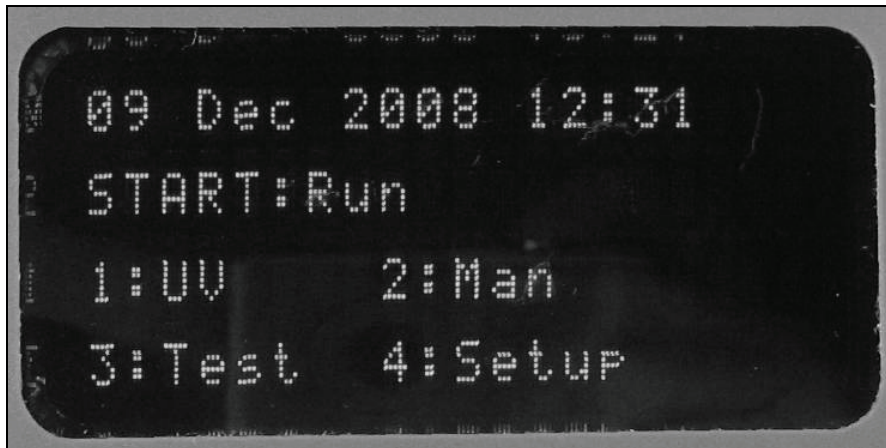

Vacuum fluorescent display (VFD).

### 3.1.3 EZ1 Advanced XL Card slot

The EZ1 Advanced XL Card slot accepts the EZ1 Advanced XL Card. Each EZ1 Advanced XL Card contains one or more protocols that allow the EZ1 Advanced XL to perform nucleic acid isolation.

<b>CAUTION</b>	<b>Damage to the instrument</b> <span style="float: right;">[C3]</span>
	Only use QIAGEN EZ1 Advanced XL Cards with the EZ1 Advanced XL. Other EZ1 Cards cannot be used with the EZ1 Advanced XL.

**Note:** Do not insert the EZ1 Advanced XL Card while the EZ1 Advanced XL is switched on. EZ1 Advanced XL Cards must not be exchanged while the EZ1 Advanced XL is switched on. Take care not to expose the EZ1 Advanced XL Card to electric shock, water, or dirt.



**EZ1 Advanced XL Card inserted into EZ1 Advanced XL Card slot.**

### **3.1.4 Status LEDs**

There are 2 light-emitting diodes (LEDs) at the front of the EZ1 Advanced XL:

- Green LED — indicates that the instrument is receiving power
- Red LED — indicates that an error has occurred

### **3.1.5 Connector panel**

The connector panel is located at the rear of the EZ1 Advanced XL.

## General Description

---

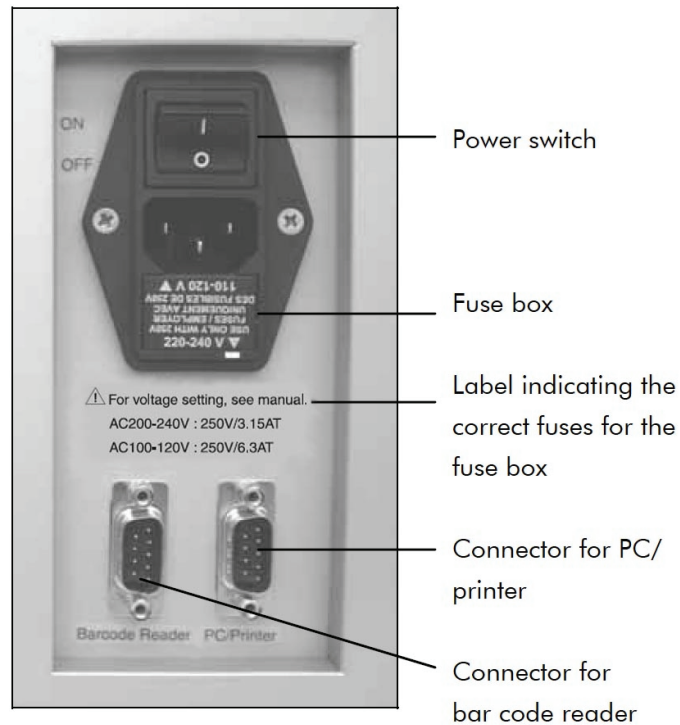

### Connector panel.

It contains the power switch, the socket for the power cord, the fuse box, and two RS232 connectors. The left connector is used to connect the bar code reader. The right connector is used to connect the EZ1 Advanced XL to a PC or an RS232 printer (optional).

## 3.2 Internal features of the EZ1 Advanced XL

The interior of the EZ1 Advanced XL contains the worktable and the pipettor head.

### 3.2.1 Worktable

The worktable contains various racks for holding the labware, samples, and reagent cartridges that are required for the protocol run. The worktable also contains a heating system for controlling the temperature of samples.

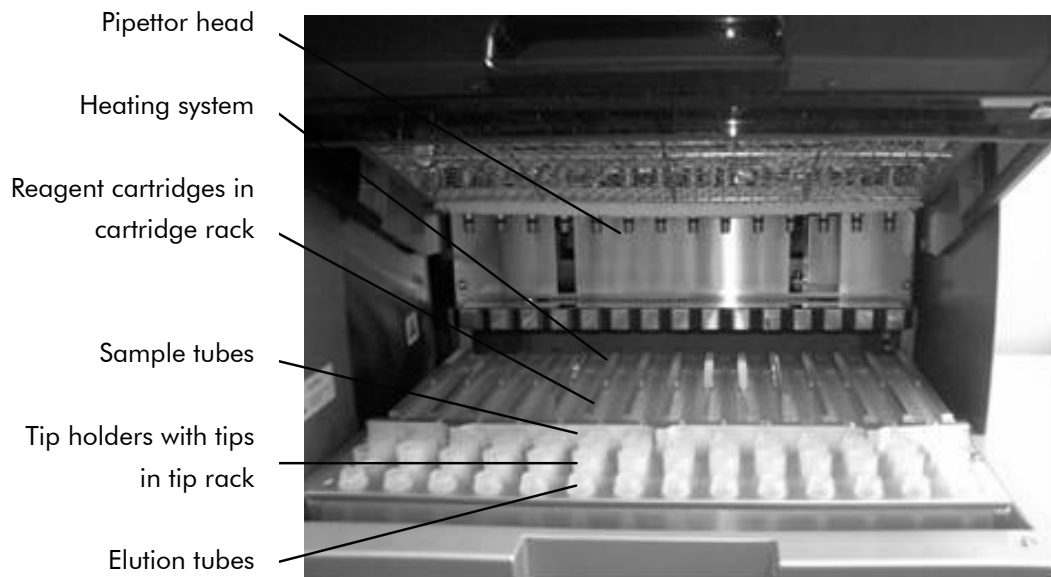

**The EZ1 Advanced XL worktable.**

### Tip rack

This rack is located at the front of the worktable. The front row holds up to fourteen 1.5 ml elution tubes. The recommended elution tubes are screw-capped, made of polypropylene, supplied by Sarstedt (cat. no. 72.692), and provided in EZ1 Kits.

The next 2 rows hold up to 28 tip holders containing filter-tips. (**Note:** Some protocols require only one row of filter-tips.) The remaining row holds up to 14 sample tubes. Sample tubes are 2 ml in volume, screw-capped, made of polypropylene, supplied by Sarstedt (cat. no. 72.693), and provided in EZ1 Kits.

## General Description

---



### **Tip rack.**

Both tip holders and filter-tips are made of polypropylene and are provided in EZ1 Kits. The filter-tips have a capacity of 50–1000  $\mu\text{l}$ .





**Tip holders and filter-tips.**

### **Cartridge rack**

This rack is located behind the tip rack and holds up to 14 reagent cartridges. Insert the cartridge rack with the arrow pointing towards the instrument.



**Cartridge rack.**

Reagent cartridges are made of polypropylene, contain prefilled reagents, and are available from QIAGEN.

## General Description

---

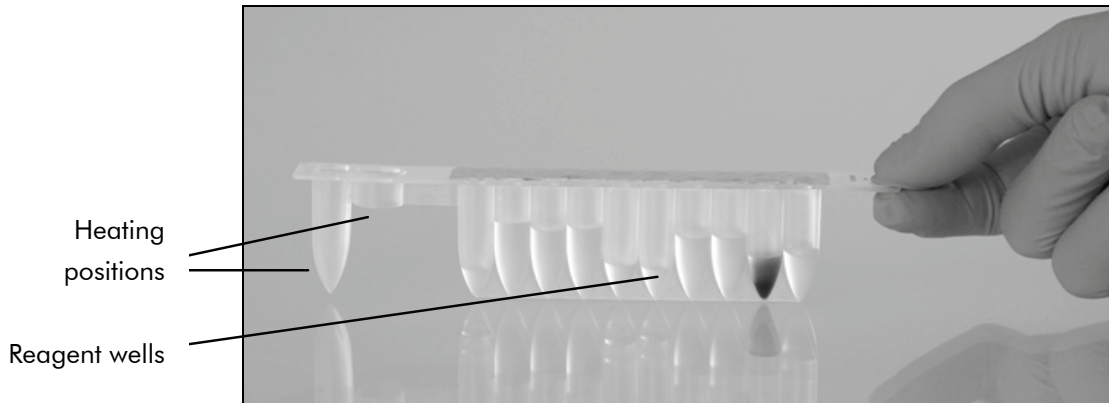

### Reagent cartridges.

A reagent cartridge consists of 10 reagent wells and 2 heating positions. One heating position is a well, the other is a slot that can accept a tube.

### Heating system

The heating system is located under the far end of the cartridge rack. It holds the heating positions of the reagent cartridges.

### Tray

The tray is located under the racks and collects any drops of liquid that may fall.



### Tray.

### **3.2.2 Pipettor head**

The pipettor head is mounted above the worktable and moves in the Z direction (i.e., up and down) in order to reach the samples and reagents on the worktable. The worktable itself moves in the Y direction (i.e., front to back) in order to present different samples and reagents under the pipettor head.

The pipettor head contains 14 high-precision syringe pumps that are connected to tip adapters that can be attached to filter-tips. The syringe pumps operate simultaneously to allow aspiration or dispensing of small volumes of liquid (50–1000  $\mu$ l) via the filter-tips.

The pipettor head also contains a magnet whose distance from the attached filter-tips can be varied. This feature allows the capture of magnetic particles that are present in the liquid aspirated into the filter-tips.

Located behind the tip adapters is the piercing unit, a row of 14 metal spikes for puncturing the foil that covers the reagent cartridges.

During operation, the piercing unit, controlled by the EZ1 Advanced XL, opens the reagent cartridges. The pipettor head then automatically picks up filter-tips from the tip rack and performs aspiration and dispensing operations at different locations on the worktable before ejecting the tips back into the tip rack.

## General Description

---

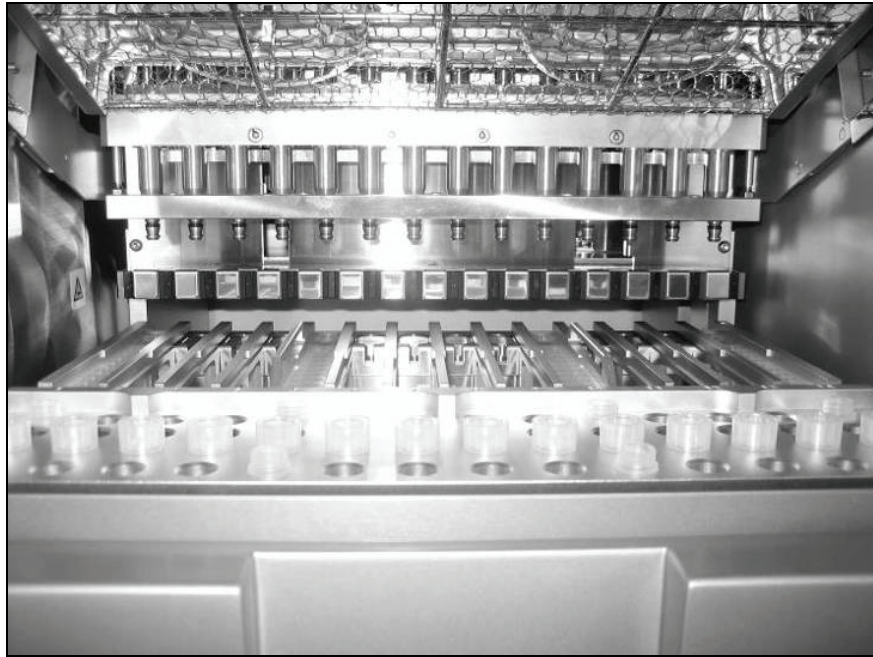

**Pipettor head.**

### 3.2.3 UV lamp

The EZ1 Advanced XL is equipped with 2 UV lamps, located under the blue EZ1 Advanced XL door. The UV lamps can be manually switched on and off in a separate menu, as described later in this manual.

Do not touch the UV lamp with your fingers since it may reduce the lamp's lifetime. The EZ1 Advanced XL door will be locked during a UV light cycle in order to protect the operator from UV radiation. The EZ1 Advanced XL will provide a warning when the lifetime of the lamp is going to expire. Call QIAGEN Technical Services when a UV lamp needs to be replaced.

<b>WARNING</b>	<b>The EZ1 Advanced XL contains 2 UV lamps</b> [W12]
	Avoid looking directly into UV light. Do not expose your skin to UV light.



**CAUTION**



**Lifetime UV lamp**

[C4]

The UV lamps need a minimum switch-on time of 20 minutes. Do not interrupt a UV light cycle before 20 minutes have passed since it will reduce the lamp's lifetime.

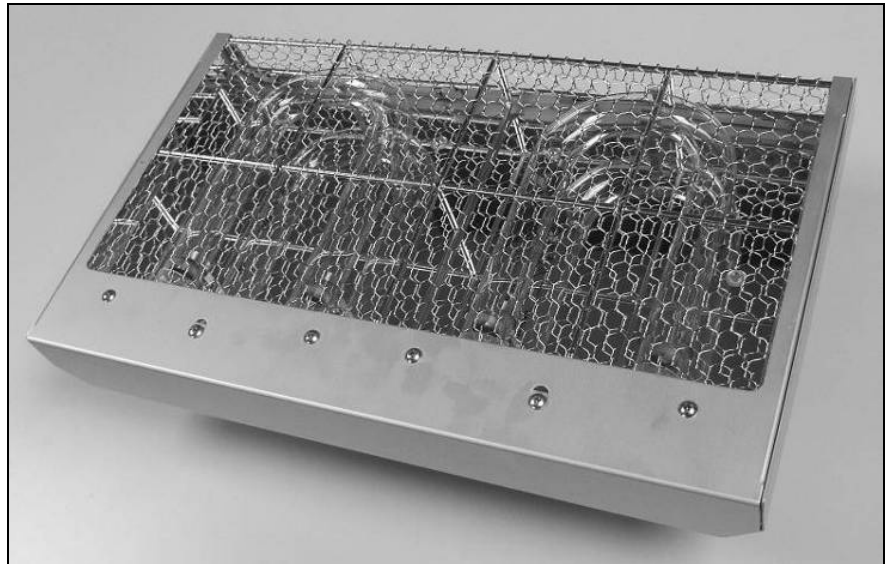

**UV lamps and reflector case.**

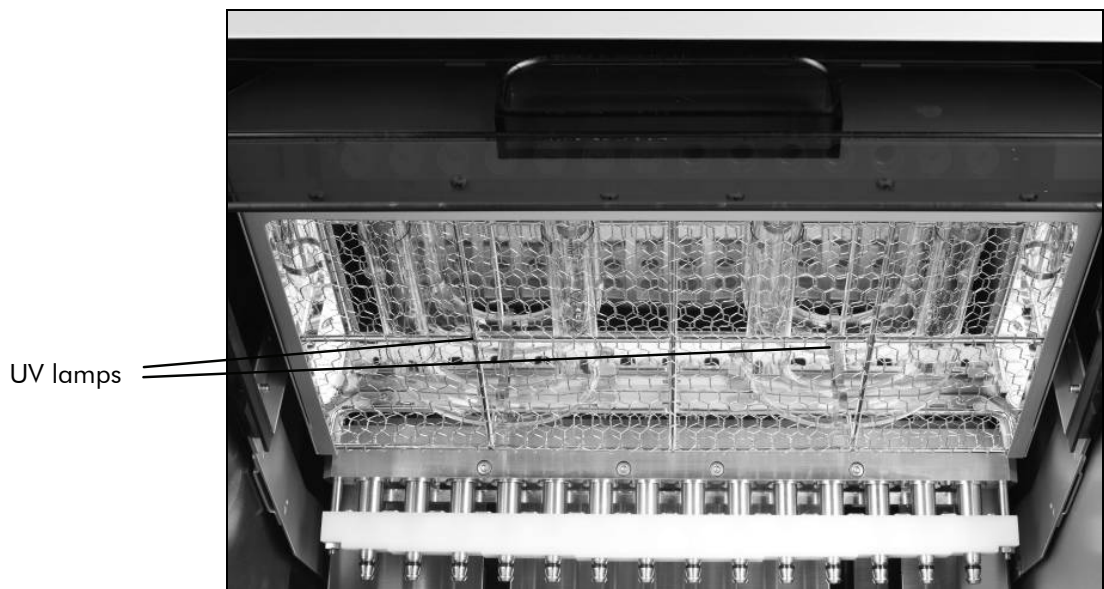

**Location of UV lamps under the EZ1 Advanced XL door.**

## General Description

---

**CAUTION****Cover of UV lamps**

[C5]

Be careful not to damage the cover of the UV lamps when loading and unloading the worktable.

## 4 Installation Procedures

The EZ1 Advanced XL is a plug-and-play instrument, making unpacking and installation easy. A member of your group who is familiar with laboratory equipment should oversee the installation.

### 4.1 Requirements

#### Site

The EZ1 Advanced XL must be located out of direct sunlight, away from heat sources, and away from sources of vibration and electrical interference. Refer to Appendix A for the operating conditions (temperature and humidity).

Use a level workbench that is large and strong enough to accommodate the EZ1 Advanced XL. Refer to Appendix A for the weight and dimensions of the EZ1 Advanced XL.

The EZ1 Advanced XL must be placed near to a properly grounded (earthed) AC power outlet. The power line to the instrument should be voltage regulated and surge protected.

### 4.2 AC power connection

#### Power requirements

The EZ1 Advanced XL operates at:

- 100–120 V AC  $\pm$  10%, 50/60 Hz, 600 VA
- 200–240 V AC  $\pm$  10%, 50/60 Hz, 600 VA

Make sure the voltage rating of the EZ1 Advanced XL is compatible with the AC voltage available at the installation site.

#### Grounding requirements

To protect operating personnel, the EZ1 Advanced XL must be correctly grounded (earthed). The EZ1 Advanced XL is equipped with a 3-conductor AC power cord that, when connected to an appropriate AC power outlet, grounds

## Installation Procedures

---

(earths) the EZ1 Advanced XL. To preserve this protection feature, do not operate the EZ1 Advanced XL from an AC power outlet that has no ground (earth) connection.

### Installation of AC power cord

Connect one end of the AC power cord to the socket located on the rear of the EZ1 Advanced XL and the other end to the AC power outlet.

The fuse box of the EZ1 Advanced XL is located under the socket for the power cord and contains 2 fuses, which are labeled as follows:

- **110–120 V** — a 6.3 A (250 V) time-delay fuse compatible with 100–120 V power supplies
- **220–240 V** — a 3.15 A (250 V) time-delay fuse compatible with 200–240 V power supplies

Before connecting the instrument to the power supply, you may need to rotate the fuse box in order to select the correct fuse. A fuse is correctly selected when its label is readable and closer to the bottom of the instrument.





Selecting the correct fuse for 200–240 V line power supply.



Selecting the correct fuse for 100–120 V line power supply.

<p><b>WARNING</b></p> 	<p><b>Electrical hazard</b> <span style="float: right;">[W13]</span></p> <p>Never install a fuse different from that specified in the user manual.</p>
---	--

### 4.3 Hardware installation

The following items are delivered:

- EZ1 Advanced XL
- International power cord set (5 countries)

## Installation Procedures

---

- PC data cable
- USB-RS232 adapter
- Cartridge rack
- Tip rack
- Tray
- O-ring (pack of 14) and silicon grease
- Fuses (1 each: 6.3 A and 3.15 A)
- Bar code reader
- *EZ1 Advanced XL User Manual*
- EZ1 Advanced XL teaching data sheet
- Packaging list
- Performance test report
- CD with EZ1 Advanced Communicator software

### 4.3.1 Unpacking the EZ1 Advanced XL

1. Cut and remove the plastic straps.

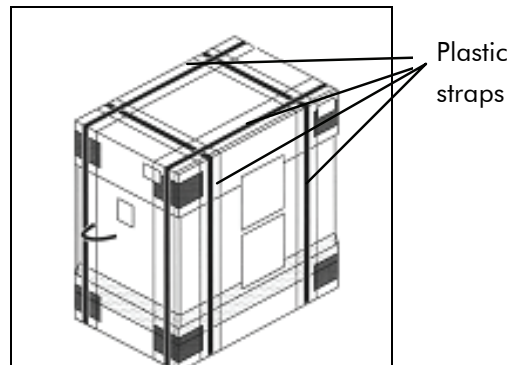

2. Remove the outer top cardboard.

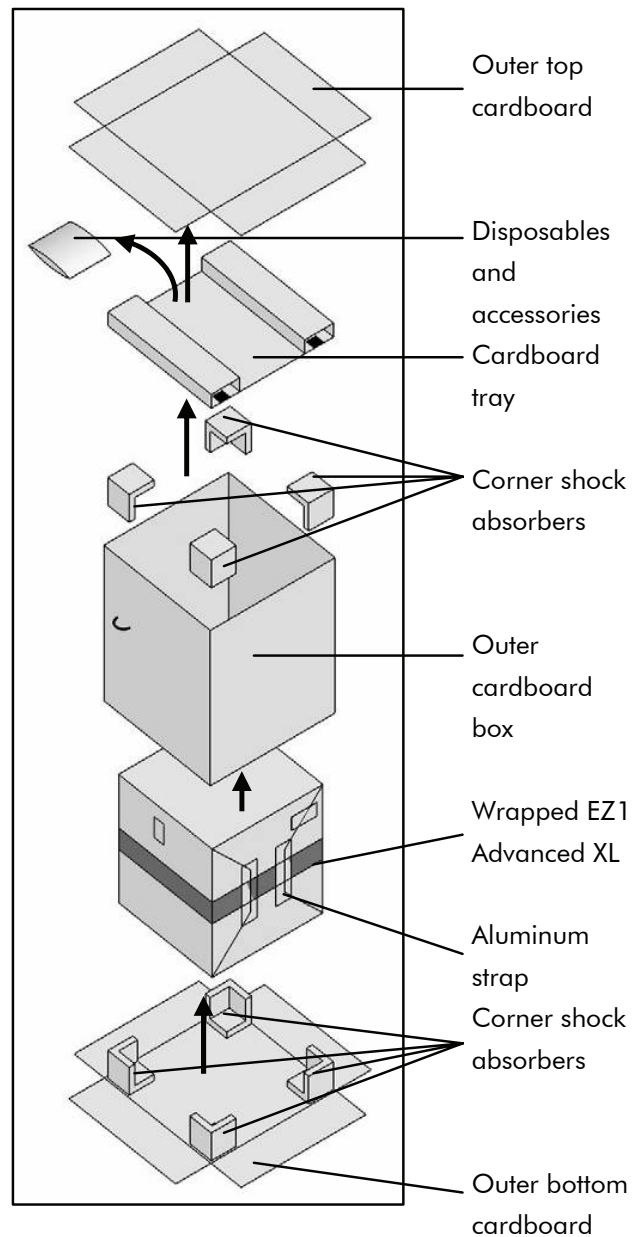

3. Take out the packages with the disposables and accessories.
4. Remove the cardboard tray.
5. Pull out the 4 corner shock absorbers at the top, and remove the outer cardboard box by pulling it up.
6. Take out the wrapped EZ1 Advanced XL, and remove the aluminum strap.

## Installation Procedures

---

7. Remove the inner top cardboard, and remove the EZ1 Advanced XL from the inner cardboard box.

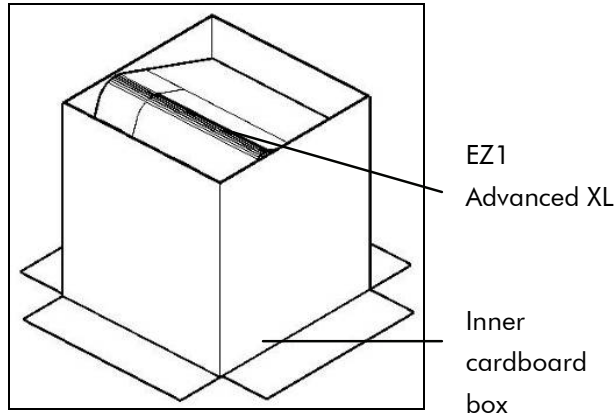

8. Remove all plastic sheets.

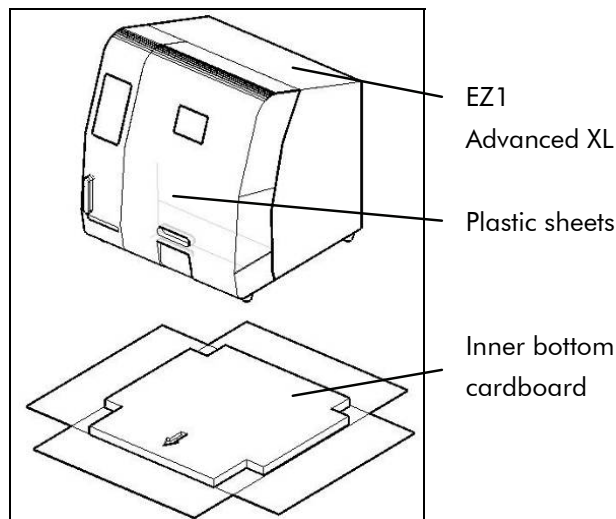

**Note:** Be careful not to damage the surface of the EZ1 Advanced XL after removing the plastic sheets.

**Note:** It is recommended to save the original packaging material for later transportation of the EZ1 Advanced XL.

### Removing the protectors for the Y- and Z-axes

During transportation, protectors prevent the moveable parts of the EZ1 Advanced XL from moving along the Y- and Z-axes. Before using the instrument, these protectors must be removed.

1. Remove the silica gel bags.

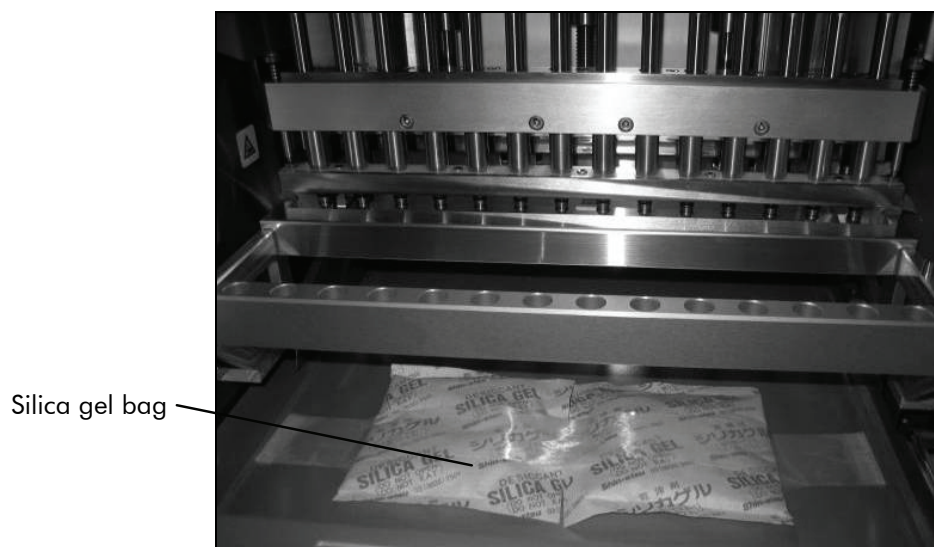

2. Push the pipettor head upward.



3. Unscrew the knurled knob located inside the instrument at the front. This knob holds the worktable in place during shipment. Keep the knurled knob in a safe place. If the instrument is shipped again, secure the worktable with the knurled knob prior to shipment.

**Note:** If the knurled knob is not removed when the EZ1 Advanced XL is switched on, error code 15 will appear because the worktable will not be able to move into its starting position. For information on error codes, see Section 7.2.

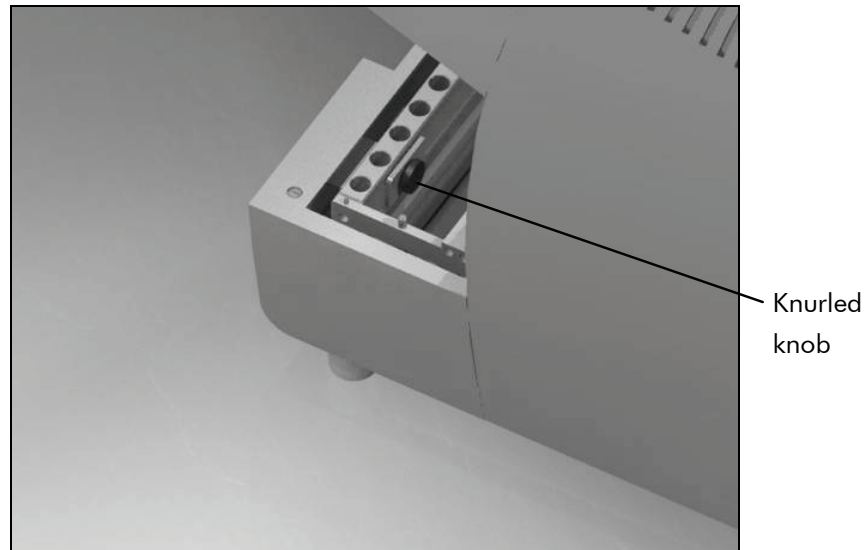

**Note:** It is recommended to save the original packaging material for later transportation of the EZ1 Advanced XL.

### 4.3.2 Installing the EZ1 Advanced XL

1. Adjust the fuse box if necessary (Section 4.2, page 4-1).
2. Connect the EZ1 Advanced XL to the power cord (Section 4.2, page 4-1).
3. Connect the handheld bar code reader to the EZ1 Advanced XL (Section 4.3.5, page 4-10).
4. Connect the PC to the EZ1 Advanced XL. Use the RS232 cable and plug it into the R232 connector labeled "PC/Printer" at the rear of the instrument (Section 3.1.5, page 3-5). Make sure that the connector is secured with the 2 screws provided.

**Note:** If your PC does not have a RS232 port, the instrument can be connected to a USB port using the USB-RS232 adapter delivered with the EZ1 Advanced XL. To use this adapter, it is necessary to install a driver, see Section 4.4.2 for more information.

5. **Optional:** If you want to use the external printer as the output device for the report file, connect the printer to the EZ1 Advanced XL (Section 4.3.4, page 4-10).
6. Insert an EZ1 Advanced XL Card into the EZ1 Advanced XL Card slot (Section 5.2.1, page 5-2).

7. Switch on the EZ1 Advanced XL. Always make sure that the door is closed before switching on the EZ1 Advanced XL. During operation, the door is locked magnetically by a solenoid. During start up, this solenoid is tested in order to check its functionality. The door must be closed for this check.

### 4.3.3 Configuring and setting up the EZ1 Advanced XL

#### Setting the installation date

The first time the EZ1 Advanced XL is switched on, it is necessary to enter the installation date. This date will be recorded in the report file described below. The installation date is also used to let the instrument know when to show the weekly and annual maintenance reminders.

SERV: SETUP SYSTEM Installation date <u>DD</u> <u>MM</u> <u>YYYY</u> Key: Up, Dn, SHIFT, ENT
---

Set the day, month, and year. Press "SHIFT"-down arrow to move the cursor to the right, from DD (day) to MM (month) to YYYY (year). Press "SHIFT"-up arrow to move the cursor left, from YYYY to MM to DD.

Press the up arrow or down arrow to increase or decrease the value of the selected field.

After setting the date, store the setting by pressing "ENT".

If you accidentally set the wrong date, call QIAGEN Technical Services for assistance.

#### Setting the serial port

Set the serial port accordingly for use with a Star printer SP500 or a PC as the output device for the report file (Section 5.10.3, page 5-30).

### Setting time and date

The EZ1 Advanced XL has an integrated clock and date device. Check the time and date and reset if necessary (Section 5.10.1, page 5-28 and Section 5.10.2, page 5-29).

### Setting the preventive maintenance reminder

The EZ1 Advanced XL reminds you when the annual maintenance is due. You can set the reminder to remind you annually or semiannually (Section 5.10.4, page 5-31).

## 4.3.4 Installing the printer (optional)

Unpack the Star printer SP500 (available from QIAGEN, cat. no. 9018464). Follow the supplier's instructions for use to carry out the following steps.

- Insert the fabric ribbon
- Insert the paper roll
- Connect the printer's data cable
- Connect the printer to an appropriate AC power outlet via the power cord
- Switch on the printer

Use the appropriate power cord, included with the printer.

Use the data cable included with the printer, with a 9-pin connector on one end and a 25-pin connector on the other end.

Connect the printer's data cable to the EZ1 Advanced XL. The connector is located at the rear of the instrument, labeled "PC/Printer" (Section 3.1.5, page 3-5). Make sure that the connector is secured with the 2 screws provided.

Check that the printer is correctly connected and working properly (Section 5.9.3, page 5-25).

## 4.3.5 Installing the bar code reader

The bar code reader is powered through the data cable. Unpack the bar code reader. Connect the cable to the bar code reader.





Connect the bar code data cable to the EZ1 Advanced XL. The connector is located at the rear of the instrument, labeled "Barcode Reader" (Section 3.1.5, page 3-5). Make sure that the connector is secured with the 2 screws provided. Switch on the EZ1 Advanced XL.

The data communication between the reader and the EZ1 Advanced XL is RS232. This must first be recognized by the bar code reader. To configure the bar code reader for RS232, scan the configuration bar code on the plastic bag of the RS232 data cable or scan the configuration bar code shown below.



**Configuration bar code RS232.**

Check if the bar code reader is correctly connected and working properly (Section 5.9.3, page 5-25).

### **4.4 Installing the PC software**

The EZ1 Advanced software "EZ1 Advanced Communicator" needs to be installed on the PC. The software is needed to receive report files from EZ1 Advanced XL and to store data on the PC hard disk.

**IMPORTANT:** To install the software, you must have administrator rights. Otherwise, error messages will appear and the software will not be installed.

### 4.4.1 System requirements

- IBM® compatible PC  
**Note:** To operate multiple (up to 4) EZ1 Advanced XL and/or EZ1 Advanced instruments with a single PC, the QIAGEN PC (cat. no. 9016643) must be used.
- Operating system: Windows® XP service pack 3 or Windows Vista Business Version Service Pack 1.
- USB-Port: USB 1.1 or higher
- Microsoft.NET Framework V2.0 (freely available for download at [www.microsoft.com](http://www.microsoft.com)) installed on the PC

The instructions in Sections 4.4.2 and 4.4.3 refer to the Windows XP operating system. Specifications for Windows Vista are similar, but the appearance and some parameters may vary.

### 4.4.2 Installing the driver of the USB-RS232 converter

#### Installing the driver

If the PC has no RS232 port, use the USB–RS232 converter. First install the driver by inserting the installation CD and following the instructions given.

The following installation wizard window appears.

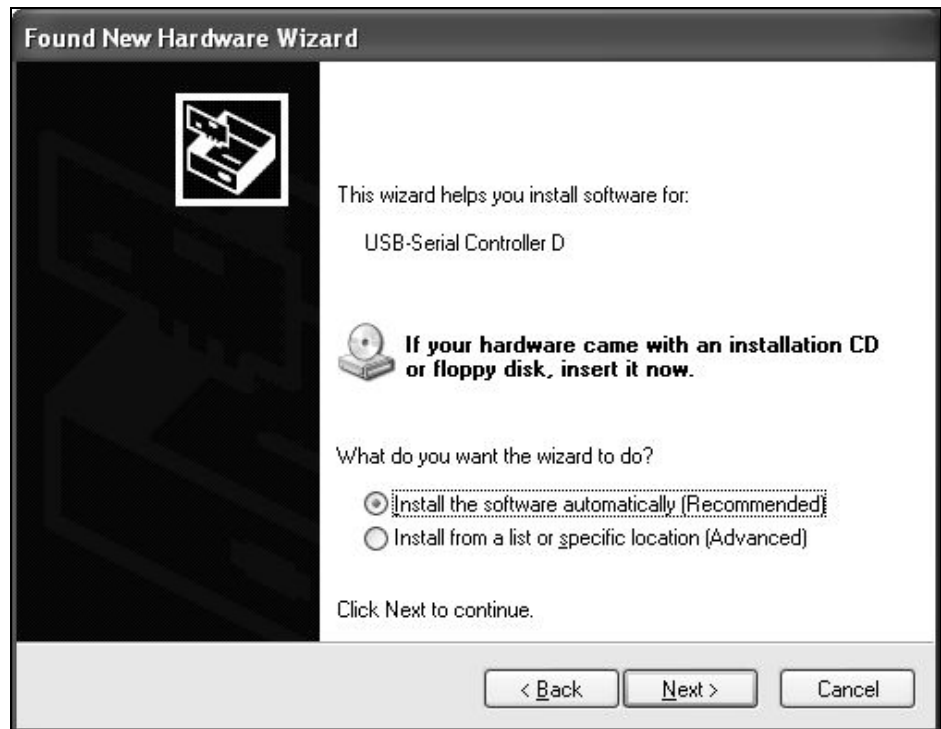

### Mapping the COM port

- Click the "Start" button on your PC and select "Settings/Control Panel".
- Double-click "System".
- Click the "Hardware" tab and select the "Device Manager" button.



- Expand "Ports" to show all available COM ports.
- Connect the converter to an open USB port on the PC. The device manager should then automatically update the COM port list. Look for the COM port named "USB to Serial Bridge".

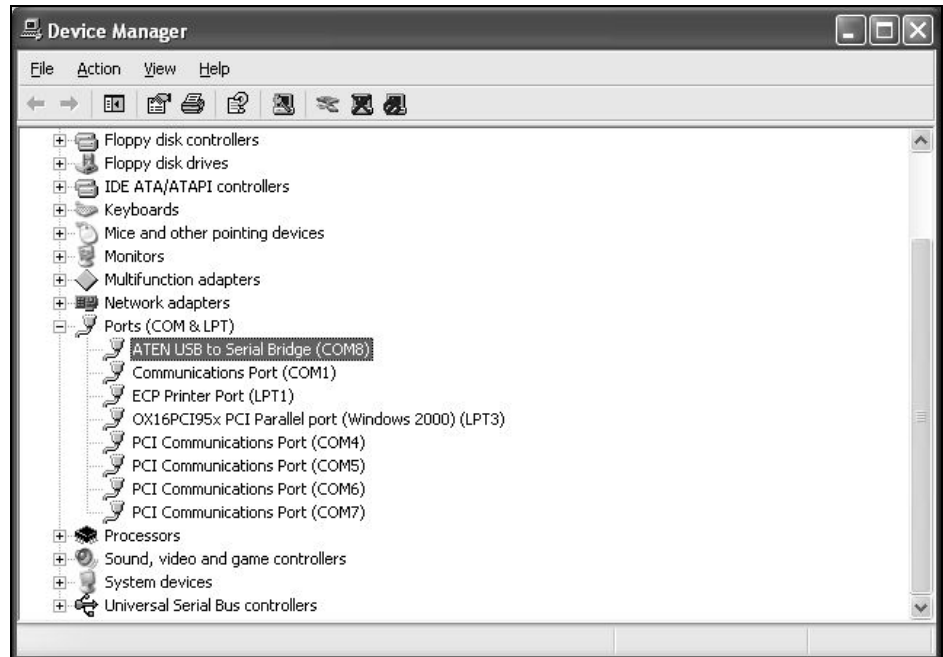

- Right click on this COM port and select “Properties”. Click the “Port Setting” tab and select the “Advanced” button.

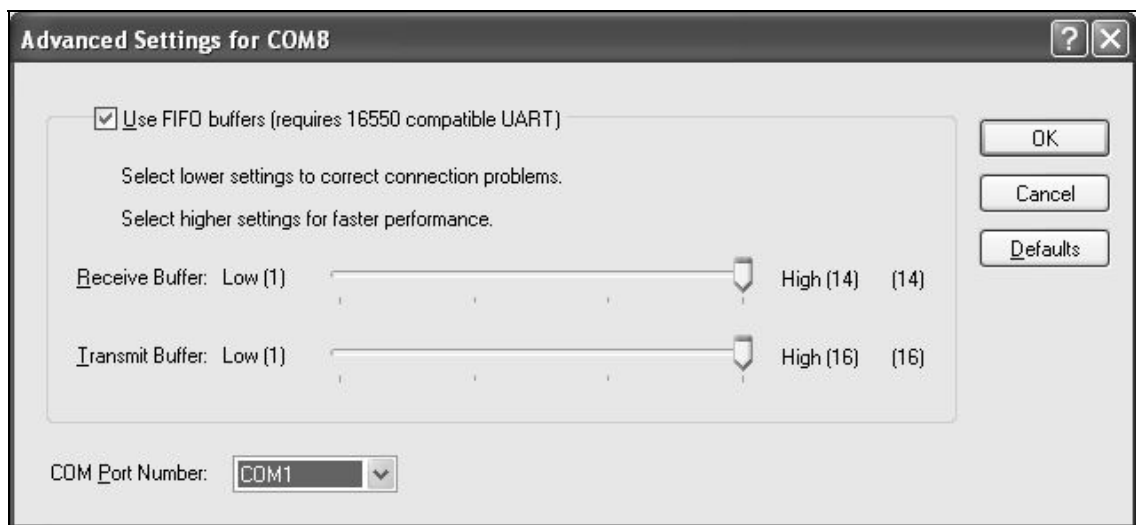

- Change the dialog field “COM Port Number” to “COM1”. The USB port is now mapped to COM port 1. Always use COM Port 1 to work with the EZ1 Advanced XL.

### 4.4.3 Installing the EZ1 Advanced Communicator software

- Insert the CD labeled “EZ1 Advanced Communicator Software” into the PC. The software will automatically start **setup.exe**.
- The installation wizard will guide you through the installation process.

**Note:** To open the user interface of the “EZ1 Advanced Communicator”, double-click on the EZ1 icon in the lower system bar.



The user interface opens.

- Select “Options” and open the “Serial port” window. Check the “COM1” box.

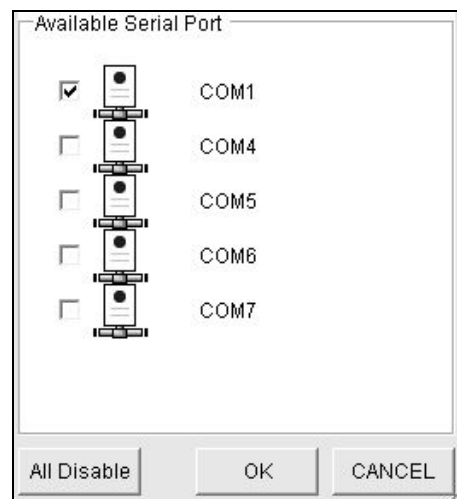

- The EZ1 Advanced Communicator software is now ready to receive data from the EZ1 Advanced XL.
- In order to check the connectivity between the PC and EZ1 Advanced XL, use the test described in Section 5.9.3.

## 4.5 Installing multiple EZ1 Advanced XL instruments

Up to 4 EZ1 Advanced XL instruments can be connected to a single PC. It is also possible to connect a combination of EZ1

Advanced XL and EZ1 Advanced instruments. The maximum number of instruments that can be connected to a single PC is 4. For this application, only the QIAGEN PC (cat. no. 9016643) can be used. This PC is equipped with a 1 x 4 Port Serial board. To set up your PC, follow the directions given below.

- Connect the large connector of the fourfold multiple cable to the rear side of the PC.

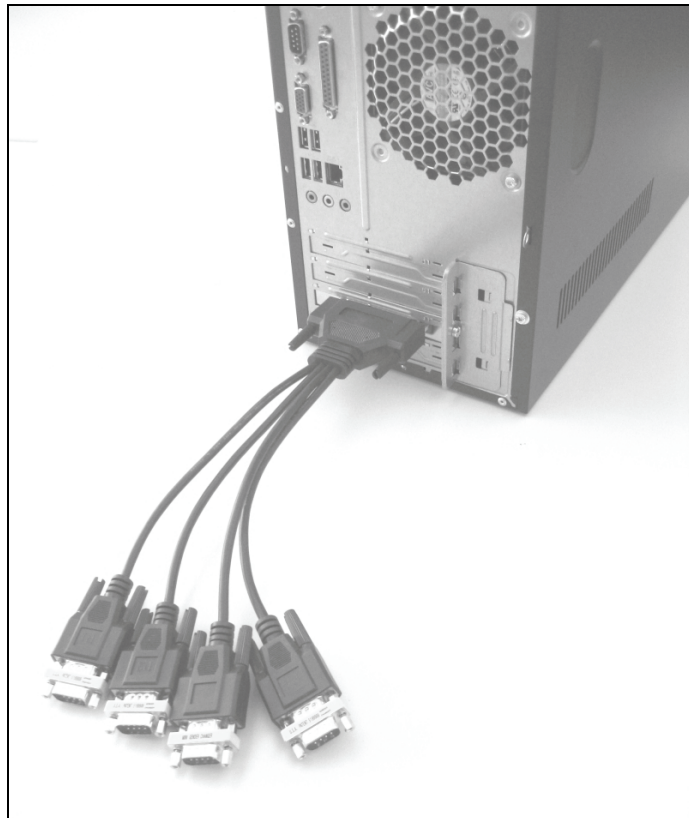

- Connect the RS232 serial cables with the small connectors of the 4-fold multiple cable. Use the screws to secure the connection.
  - To connect 2 instruments, use connectors P1 and P2.
  - To connect 3 instruments, use connectors P1, P2, and P3.
  - To connect 4 instruments, use connectors P1, P2, P3, and P4.

The connectors are labeled on the top side of the connector housing.

## Installation Procedures

---

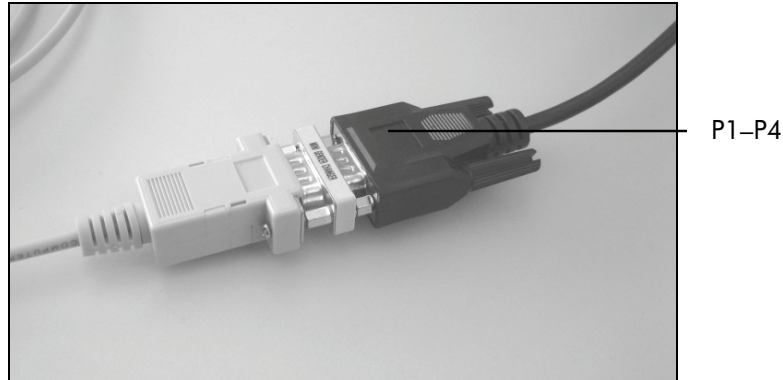

- Connect the other end of the RS232 serial cables to the EZ1 Advanced XL or EZ1 Advanced. See Section 3.1.5 for more information. Use the connector for PC/printer.
- If you use multiple EZ1 Advanced XL and/or EZ1 Advanced instruments, you do not need to install the driver for the USB-RS232 converter.
- Click the “Start” button on your PC and select “Settings/Control Panel”.
- Double-click “System”.
- Click the “Hardware” tab and select the “Device Manager” button.
- Expand “Ports” to show all available COM ports. The following window will be displayed:

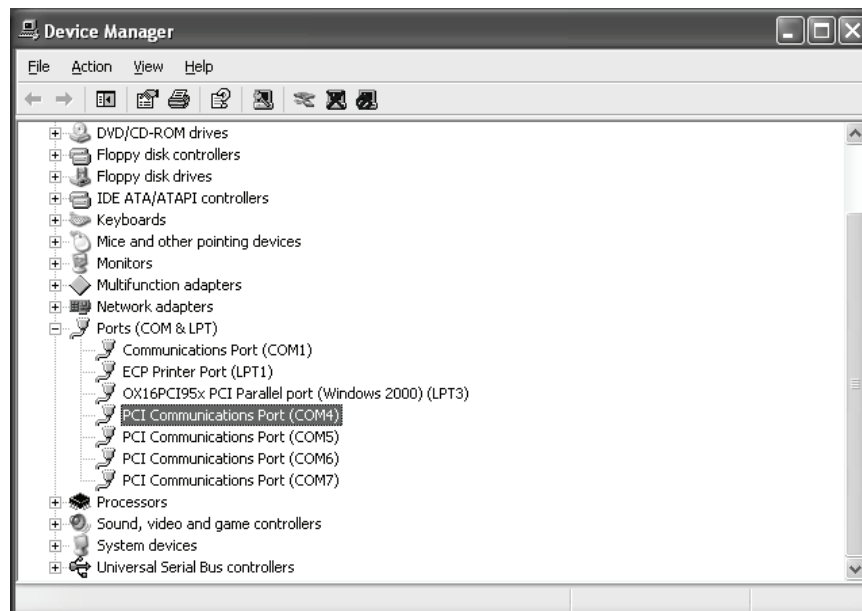



- Make sure PCI Communication Ports COM4–COM7 are displayed. These are the ports the PC uses to communicate with the EZ1 Advanced XL and/or EZ1 Advanced instruments.
- Install the EZ1 Advanced Communicator software by following the instructions in Section 4.4.3.
- Double-click the EZ1 icon in the lower system bar.
- The user interface of the “EZ1 Advanced Communicator” opens.
- Select “Options” and open the “Serial port” window.

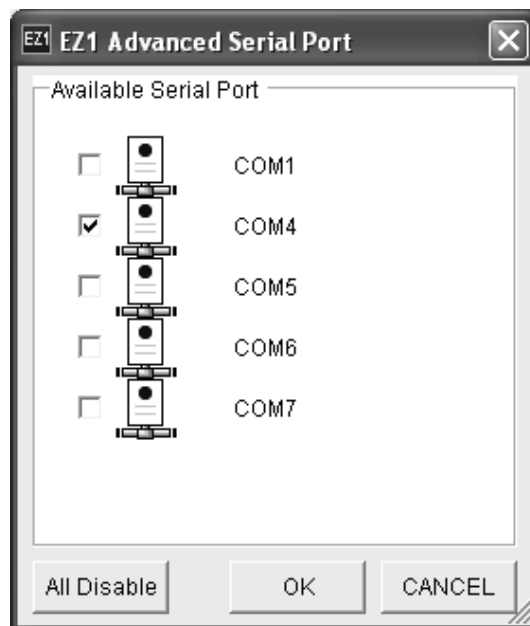

- Depending on how many instruments you are using, select COM4–COM7 starting with COM4. Depending on the PC you are using, COM3–COM6 may appear.
- The EZ1 Advanced Communicator software and the PC Windows software on the PC are now configured for use with multiple EZ1 Advanced XL and/or EZ1 Advanced instruments.
- In order to check the connectivity between the PC and EZ1 Advanced XL and/or EZ1 Advanced instruments, use the test described in Section 5.9.3.

## 4.6 Transportation and removal of the EZ1 Advanced XL

If the EZ1 Advanced XL needs to be transported, please follow your organization's instructions and guidelines. In addition, follow the steps below.

1. Decontaminate the instrument.
2. Pack the EZ1 Advanced XL by following the steps of the unpacking procedure described in Section 4.3.1 in reverse order. Use original packaging material.
3. Appendix A gives information about transportation conditions.

If the EZ1 Advanced XL needs to be sent to QIAGEN, please contact your local instrument service organization. Follow the steps below.

1. Decontaminate the instrument.
2. Follow the instruction of your local instrument service organization.

**WARNING**



**Risk of personal injury**

[W2]

Two people must carry the instrument. Use the handle attached to the box to lift the EZ1 Advanced XL. After the EZ1 Advanced XL has been unpacked, 2 people must lift the instrument. Lift the instrument by placing your hands underneath the bottom of the instrument.

## **5 General Operation**

This section describes how to operate the EZ1 Advanced XL.

Before proceeding, it is recommended that you familiarize yourself with the features of the EZ1 Advanced XL by referring to Section 3.

For information about disposable plasticware, chemicals, and storage conditions, refer to the handbook of the QIAGEN kit you are using.

### **5.1 Overview**

The steps for operating the EZ1 Advanced XL are presented below. Further details are provided later in this section.

1. Insert the EZ1 Advanced XL Card completely into the EZ1 Advanced XL Card slot.
2. Switch on the EZ1 Advanced XL.
3. After initialization, press the "START" key to start worktable setup. The protocol will lead you through the setup of the worktable by displaying messages in the display.

For details, refer to the handbook supplied with the EZ1 Kit you are using.

4. If you want the EZ1 Advanced XL to generate a report file, you will be asked to enter additional data.
5. Open the EZ1 Advanced XL door, and set up the worktable according to the messages shown in the display.
6. Close the EZ1 Advanced XL door.
7. Press "START" to start the protocol.
8. The EZ1 Advanced XL will automatically generate a report file, if requested during setup, and send it either to the PC or the printer.
9. At the end of the protocol run, you may optionally choose to perform a UV decontamination run.

## 5.2 Inserting and removing the EZ1 Advanced XL Card

**CAUTION**



**Damage to the instrument**

[C6]

The EZ1 Advanced XL Card is an integrated part of the system. Ensure that the EZ1 Advanced XL is always switched off before you insert or remove the EZ1 Advanced XL Card.

### 5.2.1 Inserting the EZ1 Advanced XL Card

1. Open the cover of the EZ1 Advanced XL Card slot.



2. Insert the EZ1 Advanced XL Card into the EZ1 Advanced XL Card slot.



Orient the card so that the picture faces to the left and the triangle symbol points towards the EZ1 Advanced XL Card slot.

## General Operation

---

Ensure that the card is completely inserted into the slot.



3. Close the cover of the EZ1 Advanced XL Card slot.
4. Switch on the EZ1 Advanced XL (Section 5.3.1, page 5-5).

**Note:** Do not remove the EZ1 Advanced XL Card while the machine is switched on.

### 5.2.2 Removing the EZ1 Advanced XL Card

1. Switch off the EZ1 Advanced XL (Section 5.3.2, page 5-6).
2. Turn the cover of the EZ1 Advanced XL Card slot.

3. Press the button at the bottom of the EZ1 Advanced XL Card slot.



The EZ1 Advanced XL Card will be ejected.

### **5.3 Switching the EZ1 Advanced XL on and off**

#### **5.3.1 Switching on the EZ1 Advanced XL**

1. Insert the EZ1 Advanced XL Card (Section 5.2.1, page 5-2).
2. Switch on the EZ1 Advanced XL at the rear power switch.
3. The display shows the following screen for a few seconds.

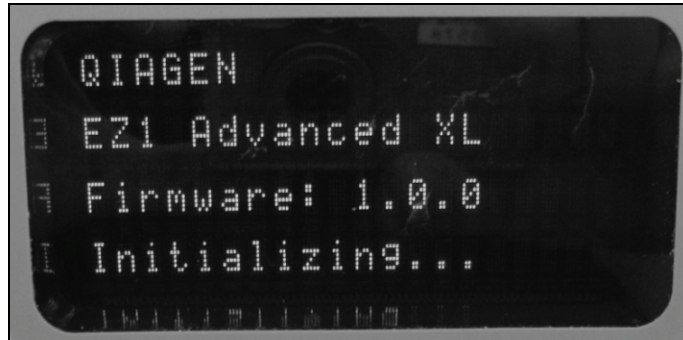

This text indicates that the EZ1 Advanced XL is initializing. All modules move to their home positions.

4. After initialization, the main menu appears.

01 Apr 2009 10:30	
START:Run	
1:UV	2:Man
3:Test	4:Setup

You can now operate the EZ1 Advanced XL.

### 5.3.2 Switching off the EZ1 Advanced XL

Switch off the EZ1 Advanced XL at the rear power switch.



## 5.4 Opening and closing the EZ1 Advanced XL door

### 5.4.1 Opening the EZ1 Advanced XL door

Reach under the door and push it up until the upper end slides into position. The door will be automatically held open.



### 5.4.2 Closing the EZ1 Advanced XL door

1. Press the door down to disengage the door. (The door is secured in the upper position with a magnet catcher.)

## General Operation

---

2. Gradually lower the door until it rests on the worktable. Take care that your fingers do not get caught between the door and worktable.



### CAUTION



#### Damage to the instrument

Do not slam the door. It may harm the filament of the UV lamp.

[C7]

## 5.5 Starting and stopping a protocol run

### 5.5.1 Starting and finishing a protocol run

After you have inserted the EZ1 Advanced XL Card and switched on the EZ1 Advanced XL, start a protocol as follows.

1. Press "START" on the control panel.

2. The protocol will lead you through the setup of the worktable by showing messages in the display.  
Follow the instructions shown in the display. For details, refer to the handbook supplied with the EZ1 Kit you are using.
3. If you want the EZ1 Advanced XL to generate a report file, you will be asked to enter additional data, such as user ID, bar code of the kit, and bar code of the samples.
4. Open the EZ1 Advanced XL door, and set up the worktable according to the messages shown in the display.  
For details, refer to the handbook supplied with the EZ1 Kit you are using.
5. Close the EZ1 Advanced XL door.  
The protocol run cannot start until the door is closed.
6. Press "START" to start the protocol run.
7. After the run is finished, remove the elution tubes, which contain the purified nucleic acid samples. Remove sample-preparation waste, and discard according to your local safety regulations.
8. The EZ1 Advanced XL will automatically generate a report file, if requested during setup, and send it either to the PC or the printer.
9. At the end of the protocol run, you may optionally choose to perform a UV decontamination run. For details, refer to the handbook supplied with the EZ1 Kit you are using.
10. Perform regular maintenance after each run as described in Section 6.1, page 6-3.

### 5.5.2 Stopping a protocol run

While the protocol run is in the phase where data is being read (e.g., sample tube bar code information), you can stop the protocol run by following the instructions below.

1. Press "STOP". The following screen appears.

```
==== PAUSE ====  
START: Continue  
STOP: Stop
```

2. Press "STOP" again to abort the protocol, or press "START" to continue the protocol.

While the protocol run is in the phase where the instrument is actively processing samples, you can abort the protocol run by following the instructions below.

1. Press "STOP". The following screen appears.

```
Do you really want to  
abort the run ?  
START: No  
STOP: Yes, abort
```

Note that the protocol has not stopped yet.

2. Press "STOP" again to abort the protocol. The protocol run will be invalid and will be marked accordingly in the report file. The following screen appears.

```
01 Apr 2009 10:30  
START:Run  
1:UV      2:Man  
3:Test    4:Setup
```

Alternatively, if you do not want to abort the protocol at this point, press the "START" key. In this case, the protocol run is not stopped and should not be affected.

3. After aborting a protocol, press "2" to display "Manual" in the display. Press "2" again to return the tips to the tip rack and to return the modules to their home positions.

## 5.6 Setting up the worktable

**Note:** For specific details about setting up the worktable, refer to the onscreen instructions, which are also included in the handbook supplied with the EZ1 Kit you are using.

### 5.6.1 Removing and replacing the tray

The tray is located under the worktable and can be removed for cleaning.

1. Switch off the EZ1 Advanced XL.
2. Remove the tip rack.
3. Push the worktable toward the back of the EZ1 Advanced XL.
4. Remove the tray using its handle.



Reverse this procedure to replace the tray. To avoid instrument damage, ensure that the tray is positioned correctly.

### 5.6.2 Loading the reagent cartridges

**Note:** Do not remove the foil from the reagent cartridges.

## General Operation

---

1. Invert the reagent cartridges several times to mix the magnetic particles. Use the same number of reagent cartridges as the number of samples to be processed.
2. Tap the reagent cartridges until the reagents are deposited at the bottom of the wells.
3. Remove the cartridge rack from the worktable.
4. Slide the reagent cartridges into the cartridge rack in the direction of the arrow, as shown below, until you feel resistance.

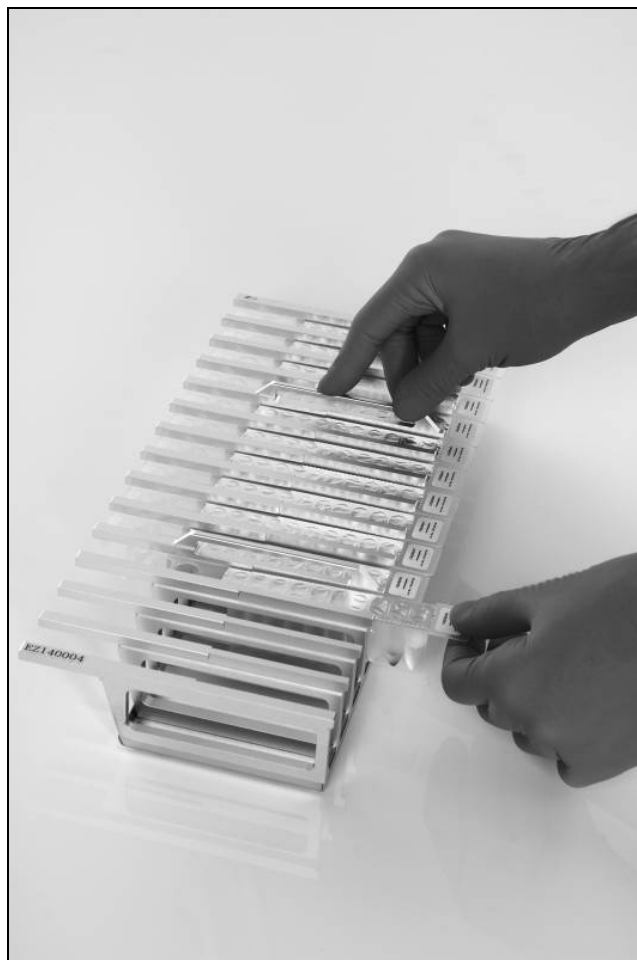

Press down the cartridges until they click into place.

**Note:** If fewer than 14 cartridges are used, they may be loaded in any order on the rack. However, when loading the other labware, make sure that they follow the same order.

5. Return the cartridge rack to the worktable.



### 5.6.3 Loading the elution tubes, filter-tips, and sample tubes

1. Remove the tip rack from the worktable.
2. Place the filter-tips into the tip holders.  
Make sure that the tips are positioned correctly in the holders.
3. Load the elution tubes, filter-tips, tip holders, sample tubes, and any other equipment or reagents as described in the messages shown in the display and described in the relevant EZ1 Kit handbook.  
Ensure that the elution tubes, filter tips, and sample tubes are loaded in the same order as the reagent cartridges.

## General Operation

---

Label the elution tubes before you load them into the rack. Make sure that the caps of the tubes are removed before you start the protocol.





4. Return the tip rack to the worktable.



Make sure that the tips, tip holders, and tip rack are correctly positioned on the worktable.

## 5.7 Using the UV lamp

At the end of a protocol run, a display message will give you the option of starting a UV decontamination run. Alternatively, you can start a UV decontamination run manually by switching on the UV lamp as described below.

**Note:** UV decontamination helps to reduce possible pathogen contamination of the EZ1 Advanced XL worktable surfaces. The efficiency of inactivation has to be determined for each specific organism and depends, for example, on sample layer thickness and sample type. QIAGEN cannot guarantee complete eradication of specific pathogens.

### 5.7.1 Switching on the UV lamp

1. Make sure that the EZ1 Advanced XL door is closed. In the main menu, press "1" to select the UV light function.

```
01 Apr 2009 10:30
START:Run
1:UV      2:Man
3:Test    4:Setup
```

The following screen appears.

```
Decontamination
Set Time: 30 min.
Key:0-9
ENT:Next ESC:Abort
```

2. Use the keys "0" through "9" to set the duration of the decontamination time. The minimum time is 20 minutes, and the maximum time is 60 minutes. The default is 30 minutes. (Pressing "ESC", will abort the procedure and return you to the main menu.)

After setting a valid time, press the "ENT" key. The following menu appears.

```
UV Decontamination
Time: 30 min.
START:Run
ESC:Back
```

If you enter an invalid decontamination time (<20 minutes or >60 minutes), the following screen will appear.

```
UV decontamination time
must be
between 20-60 min
ESC:Back
```

3. After entering a valid time, press "START" to switch on the UV lamp.

The worktable will move slowly back and forth under the UV light. During the UV run, the following screen appears.

```
UV Decontamination
Total time: TT min
Time left:  LL min
STOP:Abort
```

"TT" indicates the total time (in minutes), and "LL" indicates the amount of time left.

At the end of the run, the following screen appears.

```
Decontamination
UV lamp cooling

Please stand by
```

For user safety, the UV lamp cools for approximately 3 minutes. The EZ1 Advanced XL door cannot be opened until after the cooling time has elapsed. After cooling, the main menu appears.

### 5.7.2 Switching off the UV lamps

<p><b>CAUTION</b></p> 	<p><b>Lifetime UV lamps</b> <span style="float: right;">[C4]</span></p> <p>The UV lamps need a minimum switch-on time of 20 minutes. Do not interrupt a UV light cycle before 20 minutes have passed since it will reduce the lamp's lifetime.</p>
---	--

During a manual UV run, you can abort the run by pressing the "STOP" key. The following screen appears.

```
Attention: UV run
not finished.
START:Continue
STOP:Abort
```

Press "STOP" again to abort the UV run. Alternatively, pressing "START" will cause the UV run to continue.

### 5.7.3 Lifetime reminder of the UV lamps

The lifetime of the UV lamps is limited to 1500 cycles. The instrument will remind you when the UV lamps will expire by displaying the following screen.

```
UV Lamp Reminder:
UV lamp expires soon
UV runs left: CC
ENT=continue
```

Beginning 50 cycles before the 1500-cycle limit, the EZ1 Advanced XL will display this screen every time the instrument is switched on. "CC" indicates the number of cycles remaining. If this number is "0", both UV lamps need to be replaced. Contact QIAGEN Technical Services for replacement of the UV lamps.

### 5.7.4 UV lamps ignition error

If one or both of the UV lamps fail to ignite, the EZ1 Advanced XL will retry 2 more times. If the retries do not ignite the lamp, the following error message appears.

```
ERROR:UV Lamp
UV Lamp did not
ignite
Key:ESC
```

Contact QIAGEN Technical Services if the lamps fail to ignite.

## 5.8 Manual operation

To start manual operation, press "2" in the main menu to select the manual function.

```

01 Apr 2009 10:30
START:Run
1:UV      2:Man
3:Test    4:Setup
    
```

The manual operation screen appears.

```

MANUAL OPERATION
1:Home    2:Return Tip
3:Clean   4:Resend
ESC:Back
    
```

### 5.8.1 Manual operation "home axis"

Using the "home axis" operation, all 4 modules or any one selected module will move to their initial park positions.

Press "1" in the manual operation screen to choose the "home axis" operation. The following screen appears.

```

MANUAL OPERATION
Home axis    0:ALL
1:Y  2:Z  3:P  4:M
ESC:Back
    
```

Press "0" to "4" to select the ALL, Y, Z, P, or M functions.

ALL: All modules will move to their park positions.

Y: The worktable moves to its park position.

Z: The nozzle unit will move to its park position.

P: The piercing unit will move to its park position.

M: The magnet unit will move to its park position.

## General Operation

---

The following screen appears.

```
MANUAL OPERATION
home axis Axis
START:Run
ESC:Back
```

"Axis" indicates either the ALL, Y, Z, P, or M function. Press "START" to start the "home axis" operation or "ESC" to return to the previous screen.

During operation, the following screen appears.

```
MANUAL OPERATION
home axis Axis

Executing...
```

### 5.8.2 Manual operation "return tip"

Use the "return tip" operation to return any tips that are attached to the tip adapter. The tips will be returned to the tip rack.

Press "2" in the manual operation screen to choose the "return tip" operation. The following screen appears.

```
MANUAL OPERATION
Return tip
START:Run
ESC:Back
```

Press "START" to start the "return tip" operation or "ESC" to return to the previous screen.

### 5.8.3 Manual operation "clean"

Use the "clean" operation to get access to the piercing unit for cleaning.

The EZ1 Advanced XL door must initially be closed. Press "3" in the manual operation screen to choose the "clean" operation. The following screen appears.

```
MANUAL OPERATION
Clean piercing unit
START:Run
ESC:Back
```

Press "START" to start the "clean" operation or "ESC" to return to the previous screen.

The EZ1 Advanced XL lowers the piercing unit. The following screen appears.

```
MANUAL OPERATION
Open door and clean
piercing unit
ENT:Done
```

Open the EZ1 Advanced XL door, and clean the piercing unit as described in Section 6.1, page 6-3. After cleaning the piercing unit, close the EZ1 Advanced XL door and press "ENT" to finish the procedure.

#### 5.8.4 Manual operation "resend"

If a report file cannot be sent to the PC or printer, it is temporarily stored on the EZ1 Advanced XL. Up to 10 report files can be stored. Use the "resend" function to manually transmit the report file(s) to the PC or printer.

Press "4" in the manual operation screen to choose the "resend" operation. The following screen appears.

```
MANUAL OPERATION
Resend report file
START:Resend
ESC:Abort
```

## General Operation

---

Press "START" to start the "resend" operation or "ESC" to return to the previous screen.

While the operation is in progress, the following screen appears.

```
MANUAL OPERATION
Resend report file

Executing...
```

Alternatively, if there are no report files temporarily stored on the EZ1 Advanced XL, the following screen appears.

```
MANUAL OPERATION
No report file to
be sent
ESC:Back
```

Press "ESC" to return to the manual operation screen.

If there is an error during transmission, the following screen appears.

```
MANUAL OPERATION
Resend report file
failed
ESC:Back
```

Press "ESC". Check the connection to the PC or printer. Make sure that the PC or printer is turned on. If using a PC, make sure that the EZ1 Advanced Communicator software is installed and running on the PC.

If the transmission problem cannot be fixed, contact QIAGEN Technical Services.

## 5.9 Test

Press "3" in the main menu to select the test function.



```

01 Apr 2009 10:30
START:Run
1:UV      2:Man
3:Test   4:Setup
    
```

The test screen appears.

```

TEST
1:Axis    2:Temp
3:Serial  4:Version
ESC:Back
    
```

### 5.9.1 Test axis

Press "1" in the test screen to choose the "Axis" operation.

```

TEST
1:Axis    2:Temp
3:Serial  4:Version
ESC:Back
    
```

The following test procedures will be carried out by the EZ1 Advanced XL.

- Move modules to their home positions.
- Pick up tip 2 and release it.
- Pick up tip 1 and move it to sample position and Proc 1 position.
- Move the magnet unit to "narrow" position and then return to home.
- Aspirate and dispense to test the pipetting unit.
- Move to Proc 2–Proc 11 positions (see figure on next page).
- Move to elution position.
- Release tip 1.

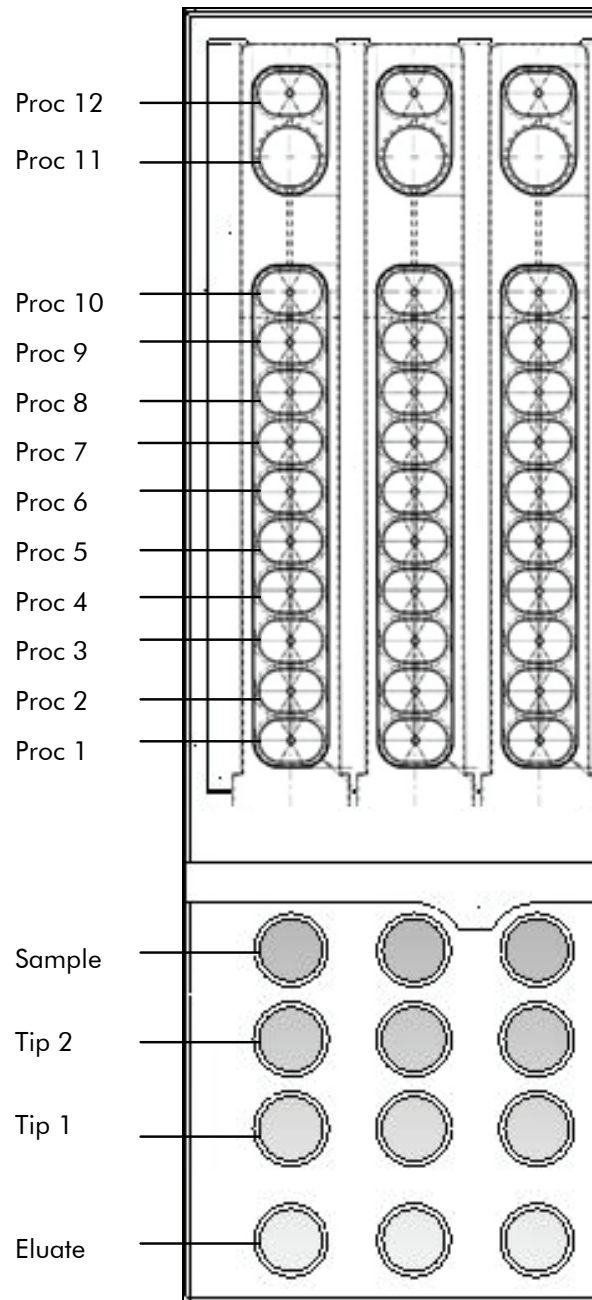

**Proc positions tested by the EZ1 Advanced XL test procedure.** First 3 rows shown of 14 in total.

### 5.9.2 Test heating block

This function tests if the heating block of the EZ1 Advanced XL is operating.

Press "2" in the test screen to choose the "Temp" operation.

```
TEST
1:Axis    2:Temp
3:Serial  4:Version
ESC:Back
```

The following screen appears.

```
TEST: TEMPERATURE
Set temp: SS.S C
Up,Dn:Set temp.
START:Run  ESC:Back
```

“SS.S” indicates the set temperature in degrees Celsius. Press the up arrow or the down arrow to increase or decrease the temperature. The upper limit is 99°C. Press “START” to start the heating process.

The following screen appears.

```
TEST: TEMPERATURE
Temp:    SS.S C
Actual: RR.R C S
ESC:Back
```

“SS.S” indicates the set temperature, and “RR.R” indicates the current temperature. “S” indicates the result, showing “O” if the temperature is within a given range or “X” if the temperature is outside the given range.

### 5.9.3 Test serial port

Press “3” in the test screen to choose the “Serial” operation.

```
TEST
1:Axis    2:Temp
3:Serial  4:Version
ESC:Back
```

## General Operation

---

The serial port test screen appears.

```
TEST: SERIAL PORT
1:PC/Printer
2:Bar code
ESC:Back
```

Press "1" to test the PC or printer communication. The following screen appears.

```
TEST: PC/Printer
Target: Type.
START:Run
ESC:Back
```

"Type" indicates whether the serial port is configured for a PC ("PC") or a printer ("Printer") (see Section 5.10.3, page 5-30).

### PC

Press "START" to send a test string to the PC. The following screen appears.

```
TEST: PC/Printer
Target: PC
Result: PASSED
ESC:Back
```

If the transmission is successful, the result will show "PASSED"; if not successful, it will show "FAILED".

### Printer

Press "START" to send a test string to the printer. The following screen appears after transmission is complete.

```
TEST: PC/Printer
target: Printer
Result: COMPLETED
ESC: Back
```

If successful, the following text is printed by the printer.

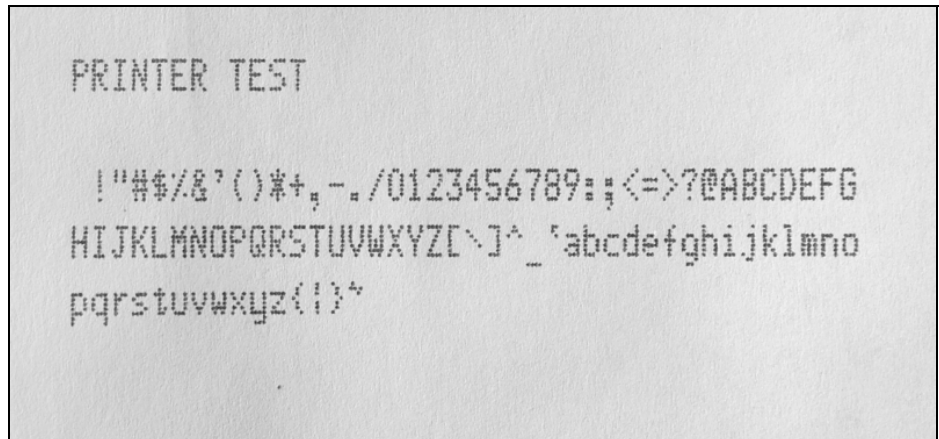

```
PRINTER TEST

!"#$%&'()*+,-./0123456789:;<=>?@ABCDEFGH
IJKLMNOPQRSTUVWXYZ[\]^_`abcdefghijklmnop
qrstuvwxyz{|}~^
```

**Printout of the printer test.**

### **Bar code reader**

Press "2" in the serial port test screen to test the bar code reader.

```
TEST: SERIAL PORT
1:PC/Printer
2:Barcode
ESC: Back
```

Use the bar code reader to read a bar code (e.g., from the Q-Card included in an EZ1 Kit). When a new bar code is read, the previous bar code will be overwritten. A beep sounds after a successful scan of the bar code.

The following screen appears, showing up to 25 digits.

## General Operation

---

```
TEST: Barcode
Result: BBBBBBBBBBBB
BBBBBBBBBBBB
ESC:Back
```

“B” indicates the individual digits of the bar code.

### 5.9.4 Test version

Press “4” in the test screen to choose the “Version” operation.

```
TEST
1:Axis      2:Temp
3:Serial    4:Version
ESC:Back
```

The following screen appears.

```
TEST: VERSION
Firmware: VersionNo
ESC:Back
```

“VersionNo” indicates the current version of the firmware.  
Press “ESC” to return to the test screen.

## 5.10 System setup

### 5.10.1 Setting the date

Press “4” in the main menu to select system setup.

```
01 Apr 2009 10:30
START:Run
1:UV      2:Man
3:Test    4:Setup
```

The system setup menu appears.

```
SYSTEM SETUP
1:Date          2:Time
3:SerialPort    4:PM
ESC:Back
```

Press "1" to change the date.

The following screen appears.

```
SETUP: DATE
DD MM YYYY
Up,Dn,SHIFT:Set
ENT:Next  ESC:Back
```

Set the day, month, and year. Press "SHIFT"-down arrow to move the cursor right, from DD (day) to MM (month) to YYYY (year). Press "SHIFT"-up arrow to move the cursor left, from YYYY to MM to DD.

Press the up arrow or down arrow to increase or decrease the value of the selected field.

After setting the date, store the setting by pressing "ENT". Alternatively, press "ESC" to leave the date unchanged.

### 5.10.2 Setting the time

Press "2" in the system setup menu to change the time.

```
SYSTEM SETUP
1:Date          2:Time
3:SerialPort    4:PM
ESC:Back
```

The following screen appears.

```
SETUP: TIME
HH:MM:SS
Up,Dn,SHIFT:Set
ENT:Next  ESC:Back
```

Press "SHIFT"-down arrow to move the cursor right, from HH (hours) to MM (minutes) to SS (seconds). Press "SHIFT"-up arrow to move the cursor left, from SS to MM to HH.

Press the up arrow or down arrow to increase or decrease the value of the selected field.

After setting the time, store the setting by pressing "ENT". Alternatively, press "ESC" to leave the time unchanged.

### 5.10.3 Setting the serial port

This setting configures the serial port for use with a printer or a PC as the output device for the report file.

Press "3" in the system setup menu to change the setting of the serial port.

```
SYSTEM SETUP
1:Date          2:Time
3:SerialPort    4:PM
ESC:Back
```

The following screen appears.

```
SETUP: SERIAL PORT
Current: CS
Set      :NS
Up,Dn,ENT,ESC
```

"CS" (current setting) indicates the current setting of the serial port as "PC", "Printer", or "Not Used".

Press the up arrow or the down arrow to change the "NS" (new setting) field to "PC", "Printer", or "Not Used".



Store the new setting by pressing "ENT". Alternatively, press "ESC" to leave the current setting unchanged.

#### 5.10.4 Setting the preventive maintenance reminder

Press "4" in the system setup menu to change the setting of the preventive maintenance reminder.

```
SYSTEM SETUP
1:Date          2:Time
3:SerialPort    4:PM
ESC:Back
```

The following screen appears.

```
SETUP: REMINDER PM
Interval

Up, Dn, ENT, ESC
```

Press the up arrow or the down arrow to change the "Interval" field to "1/2 year" (semiannual) or "1 year" (annual).

After setting the new interval, store the setting by pressing "ENT". Alternatively, press "ESC" to leave the current interval unchanged.

### 5.11 Using the bar code reader

The bar code reader is preset to read the following types of bar codes.

- 2/5 interleaved
- EAN Family
- Code 39
- Code 128

To read a bar code, press the button located on the inner side of the handle of the bar code reader. A red light appears. Hold the bar code reader in front of the bar code at a distance of approximately 20 mm. A beep will sound to

confirm that the bar code has been read. The bar code will be displayed on the screen.

- Length of barcode label: 15–65 mm
- Minimum tube diameter: 9 mm
- Maximum resolution of bar code: 0.1 mm

### 5.12 Using the external printer (optional)

The EZ1 Advanced XL allows you to confirm that a report was printed correctly before the report file is deleted. The following screen appears.

SEND REPORT  
Print out o.k ?  
1:o.k. 2:not o.k.  
ESC:Back

Press “1” to confirm that the print quality is satisfactory. The report file in the EZ1 Advanced XL will then be deleted.

Alternatively, press “2” if the print quality is not satisfactory. The report file will be printed again.

An example report file is shown on the next page.

```

REPORT - FILE EZ1 Advanced XL:
-----

Serial no. EZ1 Advanced XL:_____EZ140006
User ID:_____MaHe
Firmware version:_____V 0.0.7
Installation date of instr.:Dec 11, 2008
Weekly maintenance done on:Dec 11, 2008
Yearly maintenance done on:Oct 21, 2008
Date of last UV-run:_____Oct 29, 2008
Start of last UV-run:_____14:30
End of last UV-run:_____14:30
Status of last UV-run:___UV run aborted

Protocol name:_____DNA Tissue 081201
-----

Date of runs:_____Dec 11, 2008
Start of runs:_____13:04
End of runs:_____13:27
Status run:_____o.k
Error Code:_____---
Sample input volume[ul]:_____200
Elution volume [ul]:_____50

Channel 01:
Sample ID:_____1000
Reagent Kit number:_____9801201
Reagent Lot number:_____1151234567
Reagent Expiry date:_____1209
Assay Kit ID:_____3164
Notes:_____Sample NaCl Lsg

```

**Example printout of a report file.**

**Note:** If the printer is turned on before switching on the EZ1 Advanced XL, some additional characters will be printed before the report. To avoid this, switch on the EZ1 Advanced XL before switching on the printer.

### **5.13      Generating a report file**

The EZ1 Advanced XL will generate a report file if this option was selected during the protocol run.

The report file contains the fields described on the next pages.

<b>Parameter</b>	<b>Example output</b>	<b>Description</b>
REPORT - FILE EZ1 Advanced XL:		Title of report file
Serial no. EZ1 Advanced XL:	0301F0172	Serial number stored on the EZ1 Advanced XL
User ID:	9267	User ID, set during protocol run; Can be a number or a name scanned with the bar code reader; Maximum of 9 characters
Firmware version:	V1.0.0	Current firmware version
Installation date of instr.:	Jan 10, 2009	Installation date, set the first time the EZ1 Advanced XL is powered; Stored permanently on the EZ1 Advanced XL
Weekly maintenance done on:	Feb 10, 2009	When you accept the weekly maintenance reminder, the date is stored and is indicated here
Yearly maintenance done on:	Jan 10, 2010	When you accept the annual maintenance reminder, the date is stored and is indicated here
Date of last UV-run:	Apr 01, 2009	Date of last UV run recorded and stored
Start of last UV-run:	14:04	Start time of last UV run
End of last UV-run:	14:34	End time of last UV run

## General Operation

---

<b>Parameter</b>	<b>Example output</b>	<b>Description</b>
Status of last UV-run:	o.k.	Status of last UV run can show: o.k. UV run aborted UV lamp expired UV lamp broken
Protocol name:	Investigator	Protocol name stored on EZ1 Advanced XL Card and copied into report file
	Trace	Additional protocol name (specifies the protocol if there are multiple protocols on the EZ1 Advanced XL Card)
Date of run:	Mar 14, 2009	Time stamp for date of run given through internal clock and calendar
Start of run:	15:13	Time stamp for start of run given through internal clock and calendar
End of run:	15:43	Time stamp for end of run given through internal clock and calendar
Status run:	o.k.	The status of the run can show: o.k. not o.k. aborted
Error code:	21	See Section 7.2 for error codes
Sample input volume[ul]:	300	Sample input volume in microliters, depending on the protocol

<b>Parameter</b>	<b>Example output</b>	<b>Description</b>
Elution volume[ul]:	50	Elution volume in microliters, depending on the protocol
Channel 01:		Information for channel 1 begins here
Sample ID:	8730	Sample ID, defined by the bar code system of the user
Reagent Kit number:	9900201	Reagent kit number defined by the Q-Card
Reagent Lot number:	1151234567	Reagent lot number defined by the Q-Card
Reagent Expiry date:	Jan 14, 2009	Reagent expiry/expiration date defined by the Q-Card
Assay Kit ID:	0472	Assay kit ID (optional)
Note:	8432	Optional information, such as a name scanned by the bar code reader
Channel 02:		Information about channels 2–14 begins here (same format as above for channel 1)

If the report file could not be transmitted (e.g., if the serial connection is broken), the report will remain stored on the EZ1 Advanced XL. After connection is reestablished, use the manual transmit function to resend the report file (see Section 5.8.4, page 5-21).

Up to 10 report files can be stored temporarily on the EZ1 Advanced XL. When additional files are stored, the oldest report files will be deleted. The following screen appears.

Caution: Memory full Oldest Report will be erased. 1:Next ESC:Abort
--

Press "1" to delete the oldest report file and continue the protocol run. Alternatively, press "ESC" to abort the protocol run.

### 5.14 Using the EZ1 Advanced Communicator software

EZ1 Advanced Communicator is a software program that runs on a PC. The software receives the report file and stores it in a folder that you define. After the PC has received the report file, you can use and process the file with a LIMS (Laboratory Information Management System) or other programs.

**Note:** EZ1 Advanced Communicator software can be used with both the EZ1 Advanced XL instrument and the EZ1 Advanced instrument.

#### 5.14.1 User interface

The main window shows the list of report files received. Click the "Refresh list" button to update the list.

Select a file by single-clicking on the name. The software will perform a checksum test on the file. The result is shown under "Validity check result".



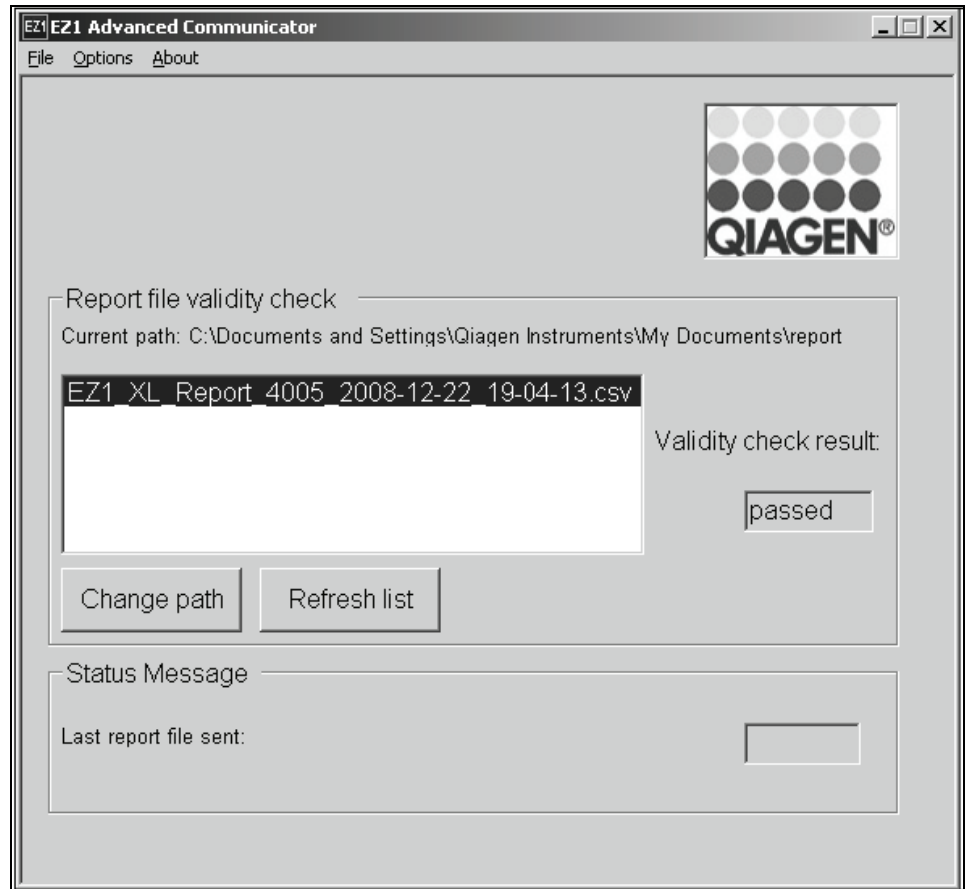

The report file name contains the following components.

- Title (e.g., EZ1\_Report)
- Serial number of the EZ1 Advanced XL
- Date in format YYYY-MM-DD
- Time in format HH-MM-SS
- File extension **\*.csv** (comma-separated value)

The date and time are when the report file was received by the PC.

The “Status Message” panel displays the name of the last report file that was sent.

Select “File” to exit the graphical user interface.

Select “Options” to display the following window showing the EZ1 Advanced XL serial ports.

## General Operation

---

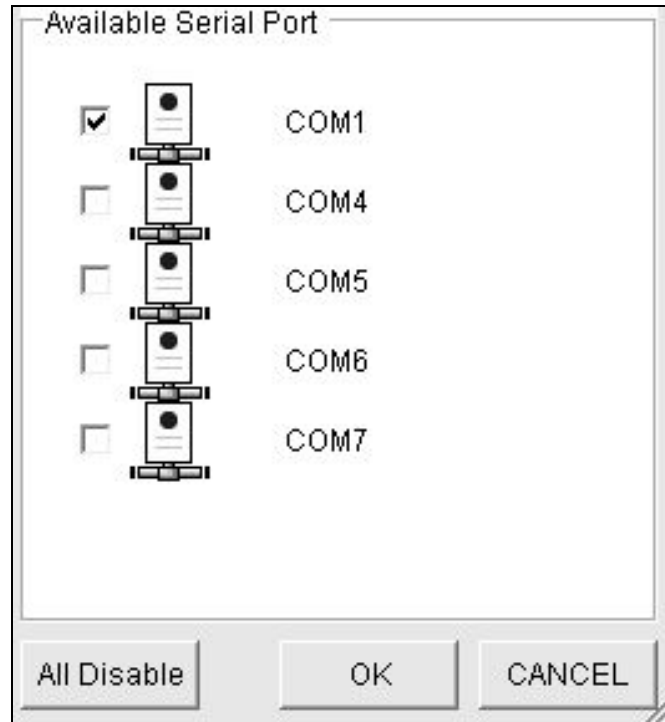

COM1 should already be selected.

You can check the serial settings by checking one of the boxes. The following window opens.

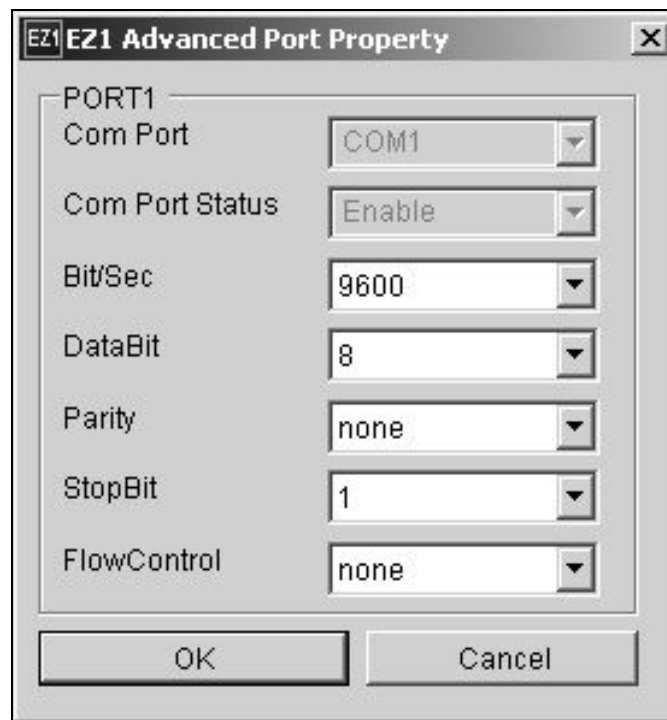

The default settings are as shown above: baud rate of 9600 bits/s, 8 data bits, parity none, 1 stop bit, flow control none.

Select “About” in the main window to show the version of the EZ1 Advanced Communicator software.



Click the “Change path” button in the main window to change the folder where the selected report file is stored. The following window opens. Browse and select the folder.

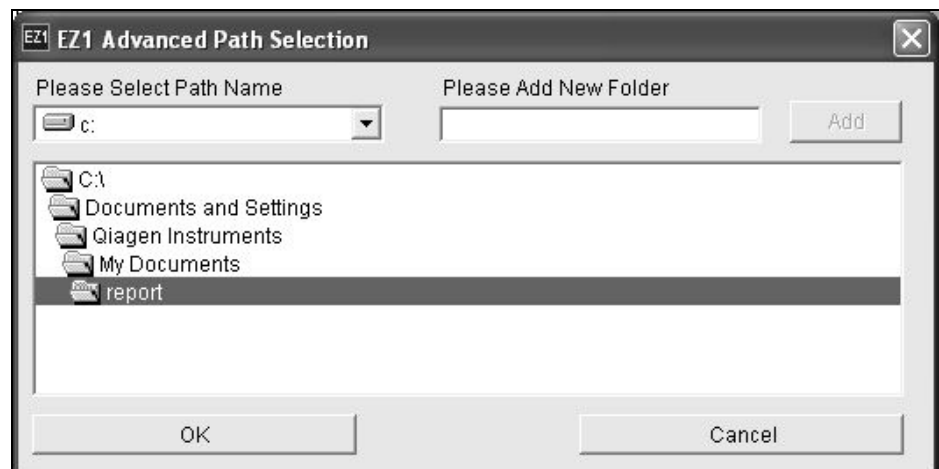

### 5.14.2 Report file in pdf format

EZ1 Advanced Communicator Version 2.0 includes the option to convert the csv report file to pdf format. This enables easy viewing of the report file. Pdf files are stored in a folder named “pdf”, which is a subfolder of the “report” folder.

## General Operation

---

If you define a new directory “xyz” using the function “Please Add New Folder”, a subdirectory named “pdf” will automatically be created in the new “xyz” folder.

The default path for the default “report” folder is:  
C:\Documents and Settings\{User}\My Documents\report

The pdf file is a more secure format that cannot be readily altered.

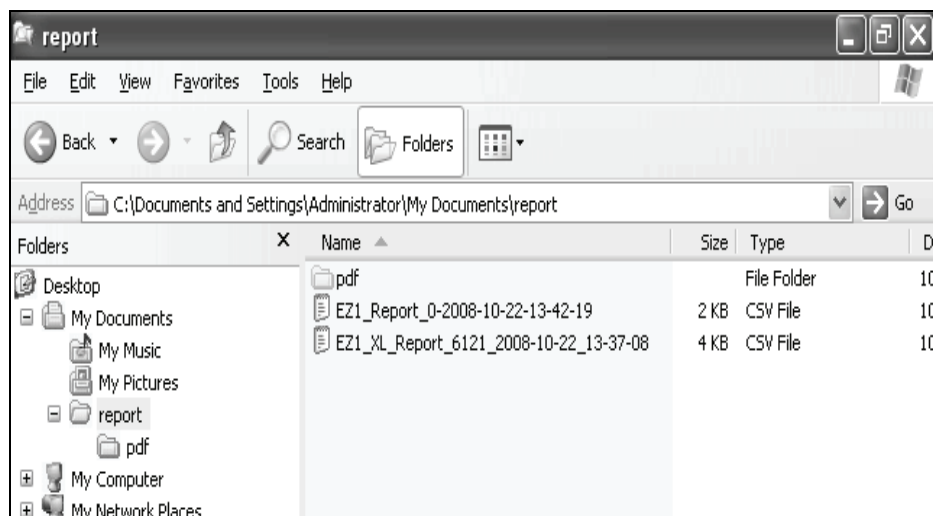

### 5.15 Using multiple EZ1 Advanced XL instruments

Up to 4 EZ1 Advanced XL instruments can send report files to a single PC. For this configuration, only the QIAGEN PC (cat. no. 9016643) can be used. For information about installing multiple EZ1 Advanced XL instruments, see Section 4.5.

**Note:** It is also possible to operate a combination of EZ1 Advanced and EZ1 Advanced XL instruments with a single PC.

### 5.16 Evaluating pipetting accuracy

The EZ1 Advanced XL Test Card (cat. no. 9018706) contains a protocol that is designed to evaluate the pipetting accuracy of the EZ1 Advanced XL. The EZ1 Advanced XL Test Card is

supplied with a QIAGEN Supplementary Protocol that guides the user through the test step by step.

The EZ1 Advanced XL Test Card also contains protocols to check the tightness of the tip adapters and to evaluate the temperature accuracy of the EZ1 Advanced XL.

## General Operation

---

This page intentionally left blank

## 6 Preventive Maintenance

This table covers the types and frequencies of maintenance required and the personnel required to carry out the maintenance.

**IMPORTANT:** Instrument covers should only be removed by QIAGEN Instrument Service Specialists during servicing.

Type of task	Frequency	Personnel
Regular maintenance	After each run on the EZ1 Advanced XL	Laboratory technicians or equivalent
Daily maintenance	At the end of each day that the EZ1 Advanced XL is run, after the regular maintenance	Laboratory technicians or equivalent
Weekly maintenance	Once per week, after the regular and daily maintenance	Laboratory technicians or equivalent
Annual preventive maintenance and servicing	Annually or semiannually (depending on how the reminder was set, see Section 5.10.4, page 5-31)	<b>QIAGEN Instrument Service Specialists only</b>

### Maintenance reminders

The EZ1 Advanced XL has a built-in clock and calendar device to remind you when the weekly or annual maintenance is due.

The weekly maintenance reminder screen appears.

## Preventive Maintenance

---

REMINDER Maintenance: Weekly 1:Done 2:Do later
---

If you have already completed the weekly maintenance, press "1" to confirm. The current date will be stored in the report file. See Section 6.3, page 6-8 for more details about weekly maintenance.

If the weekly maintenance has not been completed, you can press "2" to indicate that the maintenance will be performed later. The next time the EZ1 Advanced XL is switched on, the reminder screen will appear again.

The screen will continue to appear each time the EZ1 Advanced XL is switched on, until you press "1" to confirm that the maintenance has been completed.

The same procedure applies for the annual maintenance. The annual maintenance reminder screen appears.

REMINDER Maintenance: Yearly 1:Done 2:Do later
---

When this maintenance reminder appears, call your QIAGEN Instrument Service Specialist for annual maintenance. The annual maintenance reminder will appear every 6 months if the interval was set to "1/2 year" (see Section 5.10.4, page 5-31). Press key 2 until the maintenance has been performed on your instrument.

<b>WARNING</b>	<b>Risk of electric shock</b> <span style="float: right;">[W14]</span> Do not open any panels on the EZ1 Advanced XL. <b>Risk of personal injury and material damage</b> Only perform maintenance that is specifically described in this manual.
----------------	---





## **Servicing**



Each EZ1 Advanced XL is supplied with a one-year warranty that includes all repairs due to mechanical breakdown. Worldwide, the maximum time for response to a breakdown is 5 days. Application development, software upgrades, worktable accessories, disposable items, and replacement of spare parts such as syringes, tubing, and pipet tips are not included in the warranty.

QIAGEN offers comprehensive Service Support Agreements, including IQ/OQ, Warranty Extensions, Full Cover Support Agreements, and Preventive Maintenance Agreements. Service Support Agreements ensure high performance from your EZ1 Advanced XL. In addition, service histories are fully documented and all parts are certified and guaranteed.

Contact your local QIAGEN Instrument Service representative, or your local distributor for more information about flexible Service Support Agreements from QIAGEN.

## **6.1 Regular maintenance procedure**

Regular maintenance is required after each run on the EZ1 Advanced XL.

<p><b>WARNING</b></p> 	<p><b>Risk of personal injury and material damage</b> <span style="float: right;">[W1]</span></p> <p>Improper use of the EZ1 Advanced XL may cause personal injuries or damage to the instrument. The EZ1 Advanced XL must only be operated by qualified personnel who have been appropriately trained.</p> <p>Servicing of the EZ1 Advanced XL must only be performed by QIAGEN Instrument Service Specialists.</p>
<p><b>WARNING</b></p> 	<p><b>Hazardous chemicals and infectious agents</b> <span style="float: right;">[W15]</span></p> <p>The waste contains samples and reagents. This waste may contain toxic or infectious material and must be disposed of properly. Refer to your local safety regulations for proper disposal procedures.</p>

## Preventive Maintenance

---

If working with potentially infectious materials, such as human blood, serum, or plasma, the EZ1 Advanced XL system should be decontaminated after use (Section 6.4, page 6-9).

After running a protocol, clean the piercing unit of the pipettor head:

1. Remove sample-preparation waste, and discard according to your local safety regulations.
2. Close the EZ1 Advanced XL door.
3. Press "2" in the main menu to select the manual function.

```
01 Apr 2009 10:30
START:Run
1:UV      2:Man
3:Test    4:Setup
```

The manual operation screen appears.

```
MANUAL OPERATION
1:Home    2:Return Tip
3:Clean   4:Resend
ESC:Back
```

4. Press "3" to choose the "clean" operation. The following screen appears.

```
MANUAL OPERATION
Clean piercing unit
START:Run
ESC:Back
```

5. Press "START".

The EZ1 Advanced XL will lower the piercing unit.

The following screen appears.

MANUAL OPERATION

Open door and clean  
piercing unit

ENT: Done

6. Open the EZ1 Advanced XL door, and wipe the piercing unit using a soft tissue moistened with 70% ethanol. The piercing unit is sharp. Two pairs of gloves are recommended.

Piercing  
unit

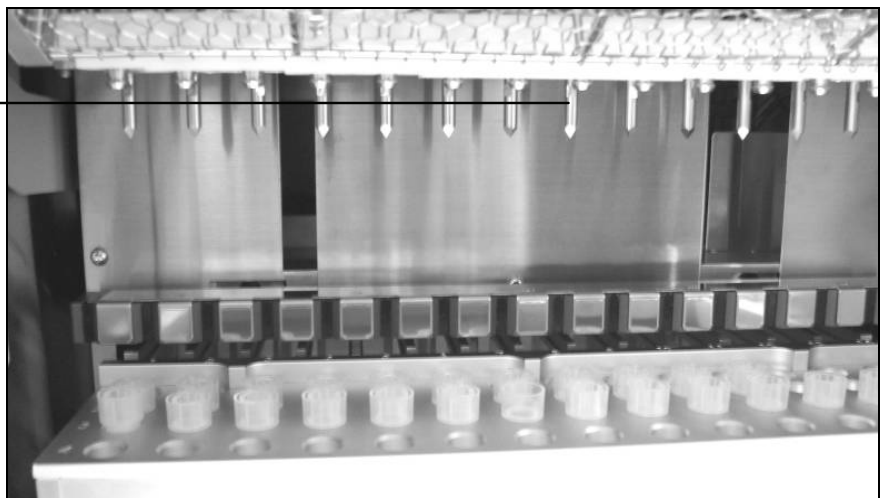

7. Wipe the piercing unit using a soft tissue moistened with distilled water.



8. Close the EZ1 Advanced XL door and press "ENT". The piercing unit returns to its original position.

## Preventive Maintenance

---

The manual operation screen appears.

MANUAL OPERATION	
1:Home	2:Return Tip
3:Clean	4:Resend
ESC:Back	

**Note:** If you press "ENT" while the EZ1 Advanced XL door is open, an error message appears (see Section 7.1.1, page 7-1).

9. Press "ESC" to return to the main menu.

01 Apr 2009 10:30	
START:Run	
1:UV	2:Man
3:Test	4:Setup

10. Open the EZ1 Advanced XL door. Clean the tray and racks with 70% ethanol and then with distilled water. See Section 5.6.1, page 5-11 for removing the tray.
11. Clean the EZ1 Advanced XL worktable with 70% ethanol and then with distilled water.
12. Wipe the other surfaces of the worktable with a diluted neutral soap solution and then with distilled water. You may now run another protocol or switch off the EZ1 Advanced XL.
13. Wipe the surface of the instrument and the blue door using a soft tissue moistened with 70% ethanol.

## 6.2 Daily maintenance procedure

### WARNING



### Hazardous chemicals and infectious agents [W15]

The waste contains samples and reagents. This waste may contain toxic or infectious material and must be disposed of properly. Refer to your local safety regulations for proper disposal procedures.

After running the last protocol of the day, perform the daily maintenance procedure:

1. Clean the piercing unit (Section 6.1, page 6-3).
2. Remove sample-preparation waste remaining, if necessary, and discard according to your local safety regulations.
3. Check that the tray is clean. If necessary, clean it with 70% ethanol, and then with distilled water.  
See Section 5.6.1, page 5-11 for removing the tray.
4. Clean the worktable and its racks with 70% ethanol, and then with distilled water.
5. Wipe the other surfaces of the EZ1 Advanced XL with diluted neutral soap solution, and then with water.

## Preventive Maintenance

---

6. Wipe the O-rings of the tip adapters with a lint-free tissue.



### 6.3 Weekly maintenance procedure

Perform the daily maintenance procedure before you perform the weekly maintenance procedure.

To maintain good contact between tip adapters and filter-tips and to prevent liquid leaking from the tips, grease the O-rings of the tip adapters every week:

1. Apply a small amount of silicon grease to the end of a filter-tip.
2. Apply the silicon grease to the surface of the O-rings.
3. Place the tip onto the pipettor head, and rotate the tip on the pipettor head to distribute the silicon grease evenly.

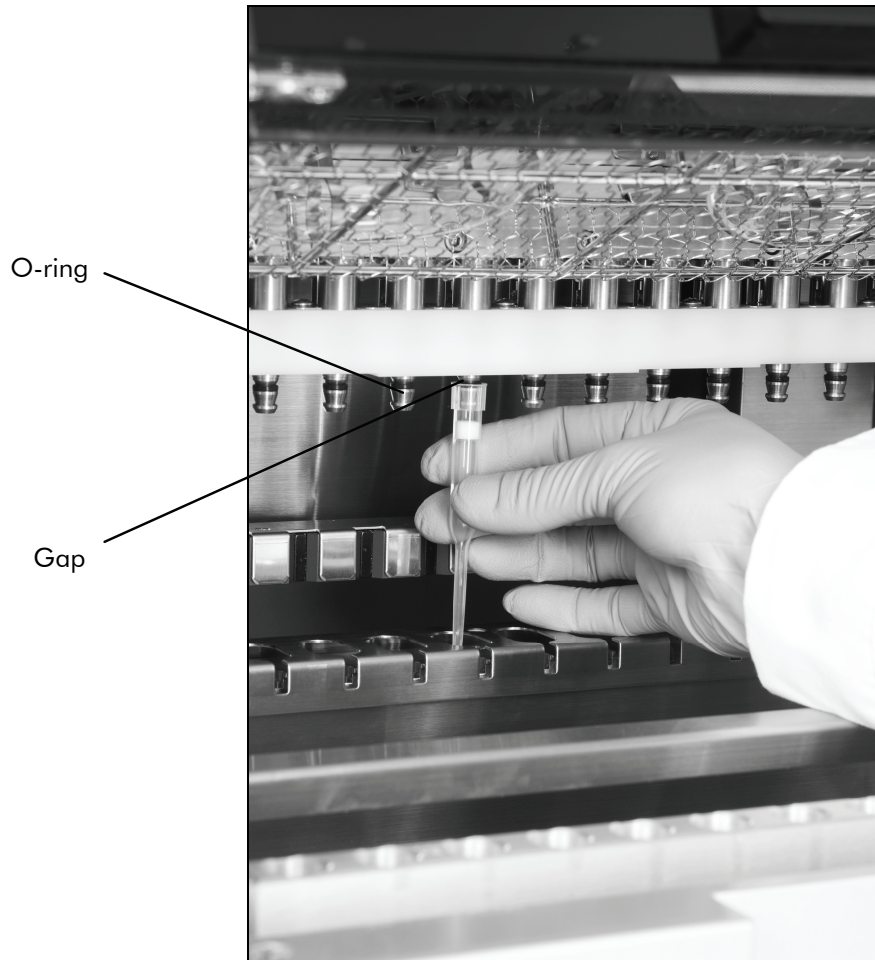

**Note:** The filter-tips should sit flush against the upper white plastic bar if the O-rings are properly greased. There should not be a gap. Excess or insufficient grease can affect the performance of the EZ1 Advanced XL.

## 6.4 Reagents for decontamination

The following disinfectants and detergents are compatible with metallic surfaces and removable components of the EZ1 Advanced XL system. Use according to manufacturers' instructions for effective disinfection.

<p><b>WARNING</b></p> 	<p><b>Toxic fumes</b> <span style="float: right;">[W16]</span></p> <p>Do not use bleach to clean or disinfect the instrument. Bleach in contact with salts from the buffers can produce toxic fumes.</p>
---	--

## Preventive Maintenance

---

- **Mikrozyd® Liquid** (Schülke & Mayr GmbH; [www.schuelke-mayr.com](http://www.schuelke-mayr.com))\* — ethanol-based disinfectant for cleaning surfaces, such as the worktable (consists of 25 g ethanol and 35 g 1-propanol per 100 g Mikrozyd Liquid)
- **Lysetol® AF or Gigasept® Instru AF** (Schülke & Mayr GmbH)\* — quaternary ammonium solution for submerging worktable items, such as holders (consists of 14 g cocospropylene-diamine-guanidine diacetate, 35 g phenoxypropanols, and 2.5 g benzalkonium chloride per 100 g, with anticorrosion components, fragrance, and 15–30% nonionic surfactants)

**Note:** If you want to use disinfectants different from those recommended, ensure that their compositions are similar to those described above. A suitable alternative to Mikrozyd Liquid is Incidin Liquid (EcoLab; [www.ecolab.com](http://www.ecolab.com)). A suitable alternative to Lysetol AF or Gigasept Instru AF is DECON-QUAT® 100 (Veltek Associates, Inc.; [www.sterile.com](http://www.sterile.com)).\*

**Note:** If you are not sure about the suitability of disinfectants or cleaning agents for use with the EZ1 Advanced XL, do not use them.

**Note:** Do not spray cleaning or disinfectant liquids onto surfaces of the EZ1 Advanced XL. Spray bottles should be used only for items that have been removed from the EZ1 Advanced XL.

\* This is not a complete list of suppliers and does not include many important vendors of biological supplies.



## 7 Troubleshooting

### 7.1 Detecting an error

#### 7.1.1 EZ1 Advanced XL door errors

If the EZ1 Advanced XL door is open when you start a protocol run, the following error screen will be displayed.

ERROR: Door open!  
Close the door and  
retry.  
ESC:Retry

Close the door and press "ESC" to continue with the protocol run.

If the door sensor indicates that the EZ1 Advanced XL door is closed but the locking mechanism is defective, the following error screen will be displayed.

ERROR: Can not lock.  
Close the door and  
retry.  
ESC:Retry

Press "ESC" to retry. If the error persists, contact QIAGEN Technical Services.

#### 7.1.2 Other errors

If a protocol run is interrupted due to an error:

- The red LED flashes
- An alarm sounds
- The display will show an error message

## Troubleshooting

---

```
ERROR: ErrCode  
Line: LineNo  
  
ESC:Next
```

The first line shows the Error Code. Refer to the error code list in section 7.2 for more information about the error.

The second line indicates the line number of the protocol at which the error occurred.

Record the error code and the line number, and contact QIAGEN Technical Services. Then reset the EZ1 Advanced XL by following the procedure given below.

1. Press "ESC" to display the main menu.
2. Ensure that the EZ1 Advanced XL door is closed.
3. Press "2" to select the manual function.

```
01 Apr 2009 10:30  
START:Run  
1:UV      2:Man  
3:Test    4:Setup
```

4. Press "2" to return the tips to the tip rack and to return the modules to their home positions.

```
MANUAL OPERATION  
1:Home    2:Return Tip  
3:Clean   4:Resend  
ESC:Back
```

5. Press "ESC" to return to the main screen.  
Another protocol can now be run.

**Note:** It is not possible to continue a protocol run that has been interrupted due to an error.

## **7.2 Error codes**

<b>Error code</b>	<b>Description</b>
10	Home sensor not activated during an operation other than a protocol
11	End-limit sensor not activated during an operation other than a protocol
12	Home sensor of the pipettor head (Z-axis) not activated during a protocol run
13	Home sensor of the plunger unit (P-axis) not activated during a protocol run
14	Home sensor of the magnet unit (M-axis) not activated during a protocol run
15	Home sensor of the worktable (Y-axis) not activated during a protocol run (e.g., if the knurled knob used for transportation was not removed, this error will occur [see Section 4.3.1])
16	End-limit sensor of the pipettor head (Z-axis) not activated during a protocol run
17	–
18	–
19	End-limit sensor of the worktable (Y-axis) not activated during a protocol run
20	Motor for pipettor head movement (Z-axis) does not respond
21	Motor for plunger/piercing unit movement (P-axis) does not respond
22	Motor for magnet-unit movement (M-axis) does not respond
23	Motor for worktable movement (Y-axis) does not respond during a protocol run

## Troubleshooting

---

<b>Error code</b>	<b>Description</b>
24	Door open when starting an operation
25	Bottom sensor of pipettor head (Z-axis) activated during an operation
26	Communication error between heating block and temperature controller, or card is not an EZ1 Advanced XL Card
27	Communication error between motors and driver board
28	–
29	–
30	Protocol import error
31	Door lock error during operation
32–99	–
100	Protocol checksum error
101	VP table checksum error
102–109	–
110	System error

---

## 8 Glossary

<b>Term</b>	<b>Description</b>
Bar code reader	A handheld device that enables scanning of bar codes and conversion of them into data that is transmitted to the EZ1 Advanced XL.
Cartridge rack	A metal rack that accommodates reagent cartridges on the worktable.
Connector panel	The panel on the rear of the EZ1 Advanced XL. It contains the power switch, the socket for the power cord, the fuse box, and a connector for a computer cable.
Control panel	The user interface that allows the user to operate the EZ1 Advanced XL. The control panel consists of a VFD and a keypad.
Elution tube	A polypropylene, screw-capped 1.5 ml tube for collecting purified nucleic acids. The recommended elution tubes are screw-capped, made of polypropylene, supplied by Sarstedt (cat. no. 72.692), and provided in EZ1 Kits.
Error code	A 2- or 3-digit number that indicates a specific error of the EZ1 Advanced XL.
EZ1 Advanced Communicator	A software program that runs on a PC and enables reception and storage of report files from the EZ1 Advanced XL.
EZ1 Advanced XL Card	A card that contains one or more protocols for the EZ1 Advanced XL and is inserted into the instrument.
EZ1 Advanced XL Card slot	A slot at the front of the EZ1 Advanced XL that accepts an EZ1 Advanced XL Card.

## Glossary

---

<b>Term</b>	<b>Description</b>
EZ1 Advanced XL door	The main door at the front of the EZ1 Advanced XL. When open, it provides complete access to the worktable.
EZ1 Kits	Kits supplied by QIAGEN containing reagents, reagent cartridges, and plasticware for use with EZ1 instruments.
Filter-tip	An item of labware that is picked up by a tip adapter during operation of the EZ1 Advanced XL. Liquid is aspirated into and dispensed from a filter-tip. A filter-tip is also the location where separation of magnetic particles occurs.
Heating system	A component of the EZ1 Advanced XL that accommodates the heating positions of the reagent cartridges and heats samples.
O-ring	A ring that is fitted at the bottom of a tip adapter. It is required for good contact between the tip adapter and a filter-tip.
Pipettor head	The component of the EZ1 Advanced XL that aspirates and dispenses liquid and separates magnetic particles. The pipettor head moves up and down above the worktable and contains 14 syringe pumps, each of which is connected to a tip adapter.
Protocol	A set of instructions for the EZ1 Advanced XL that allows the instrument to automate a nucleic acid purification procedure. Protocols are run using the control panel.
Reagent cartridge	An item of labware that contains 10 wells and 2 heating positions. One heating position is a well, the other is a slot that can accept a tube. A reagent cartridge is prefilled with reagents and included in EZ1 Kits.

---

<b>Term</b>	<b>Description</b>
Report file	A data file generated by the EZ1 Advanced XL containing system and run parameters. The report file can be sent directly to a printer or to a PC running EZ1 Advanced Communicator software.
Sample tube	A polypropylene, screw-capped 2 ml tube for holding a sample containing nucleic acids to be purified. Sample tubes are 2 ml in volume, screw-capped, made of polypropylene, supplied by Sarstedt (cat. no. 72.693), and provided in EZ1 Kits.
Tip adapter	One of 14 metal probes installed on the pipettor head. During operation of the EZ1 Advanced XL, the tip adapters pick up filter-tips from the worktable.
Tip holder	A polypropylene tube that holds a single filter-tip. Tip holders are loaded onto the tip rack.
Tip rack	A metal rack that accommodates tip holders containing filter-tips on the worktable. The tip rack also accommodates sample tubes and elution tubes.
Tray	A metal tray that is located under the worktable. It collects any drops of liquid that may fall.
UV lamp	A light source of ultraviolet light for decontamination.
VFD	Vacuum fluorescence display, a message-display screen using vacuum-tube technology.
Worktable	The surface of the EZ1 Advanced XL that contains racks and is where samples, reagent cartridges, and disposable labware are loaded. The worktable moves backwards and forwards to present different samples and reagents under the pipettor head.

This page intentionally left blank



## Appendix A

### Technical data

QIAGEN reserves the right to change specifications at any time.

### Environmental conditions

#### Operating conditions

Power	100–120 V AC, 50/60 Hz, 600 VA (North America and Japan) 200–240 V AC, 50/60 Hz, 600 VA (Europe) Mains supply voltage fluctuations are not to exceed 10% of nominal supply voltages.
Fuses	6.3 A (250 V) time-delay fuse (for 100–120 V AC) 3.15 A (250 V) time-delay fuse (for 200–240 V AC)

<p><b>WARNING</b></p> 	<p><b>Electrical hazard</b> <span style="float: right;">[W13]</span></p> <p>Never install a fuse different from that specified in the user manual.</p>
---	--

Overvoltage category	II
Air temperature	15–30°C (59–86°F)
Relative humidity	15–75% (noncondensing)
Altitude	Up to 2000 m (6500 ft.)
Place of operation	For indoor use only

## Appendix A

---

Pollution level 2

Environmental class 3K2 & 3M2 (IEC 60721-3-3)

### Transportation conditions

Air temperature  $-25^{\circ}\text{C}$  to  $60^{\circ}\text{C}$  ( $-13^{\circ}\text{F}$  to  $140^{\circ}\text{F}$ ) in manufacturer's package

Relative humidity Minimum 15% to maximum 75% (noncondensing)

Environmental class 2K2 & 2M2 (IEC 60721-3-2)

### Storage conditions

Air temperature  $5^{\circ}\text{C}$  to  $40^{\circ}\text{C}$  ( $41^{\circ}\text{F}$  to  $104^{\circ}\text{F}$ ) if in manufacturer's package

Relative humidity Minimum 15% to maximum 75% (noncondensing)

Environmental class 1K2 & 1M2 (IEC 60721-3-1)

### Mechanical data and hardware features

Dimensions Width: 0.51 m (20 in.)  
Height: 0.57 m (22.5 in.)  
Depth: 0.51 m (20 in.)  
0.57m (22.5 in.) including power connector

Mass 48 kg (128 lb.)

Instrument features	<ul style="list-style-type: none"><li>■ Automated nucleic acid isolation using magnetic particles</li><li>■ Desktop instrument</li><li>■ Protocols stored on EZ1 Advanced XL Cards</li><li>■ To be used only with QIAGEN EZ1 Kits</li><li>■ Aspirates and dispenses 14 samples or reagents simultaneously using a 14-channel pipettor head</li><li>■ Separates magnetic particles using patented technology</li><li>■ Processes up to 14 samples in one run</li><li>■ Controlled through VFD user interface</li><li>■ Temperature control through a heating system</li></ul>
Data tracking	Bar code reader and manual keyboard enable data tracking of samples and consumables. System and run parameters are stored in a report file that can be directly printed or transferred to a PC. Report files can be processed with a LIMS (Laboratory Information Management System) or other programs.

## Appendix A

---

Pipettor head	<p>Contains 14 high-precision syringe pumps, each containing a tip adapter that attaches to filter-tips. Each tip aspirates and dispenses 50–1000 <math>\mu</math>l liquid.</p> <p>Pipetting accuracy is as follows:</p> <p>50–100 <math>\mu</math>l: <math>\pm</math> 5%</p> <p>100–1000 <math>\mu</math>l: <math>\pm</math> 2%</p> <p>Syringe pumps are air-filled.</p> <p>Liquids containing salts, alcohol, solvents, and/or magnetic particles can be aspirated and dispensed.</p> <p>Air gaps can be aspirated to prevent aspirated liquid from dripping.</p> <p>The pipettor head contains a magnet that allows separation of magnetic particles from the aspirated liquid.</p> <p>Filter-tips are picked up from the tip rack and ejected back into the tip rack.</p> <p>The pipettor head moves in the Z direction above the worktable.</p>
Heating system	<p>Accommodates the heating positions of reagent cartridges and has a temperature range of between ambient temperature and 95°C (203°F).</p> <p>Heating block accuracy at 60°C is <math>\pm</math> 2°C.</p>
Filter-tips	<p>Attach to the tip adapters of the pipettor head to allow liquid aspiration and dispensing. Capacity of 50–1000 <math>\mu</math>l.</p> <p>The EZ1 Advanced XL accommodates up to 28 tip holders, each containing a filter-tip, in the tip rack on the worktable.</p>

Labware	<p>Reagents are loaded onto the worktable using the reagent cartridges. These cartridges are already prefilled with reagents by QIAGEN.</p> <p>Up to 14 reagent cartridges are accommodated together on the worktable by a cartridge rack.</p> <p>Samples are loaded onto the worktable using 2 ml sample tubes.</p> <p>Steps that require heating occur on the heating system, which accommodates the heating positions of the reagent cartridges.</p> <p>Purified nucleic acids are collected in 1.5 ml elution tubes.</p>
UV lamp	<p>Produces UV light with wavelength of 253.7 nm, corresponding to ultraviolet light type C.</p>
Capacity	<p>Up to 14 samples per run</p>

## Waste Electrical and Electronic Equipment (WEEE)

This section provides information about disposal of waste electrical and electronic equipment by users in the European Union.

The European Directive 2002/96/EC on WEEE requires proper disposal of electrical and electronic equipment when it reaches its end of life. The crossed-out wheeled bin symbol (see below) indicates that this product must not be disposed of with other waste; it must be taken to an approved treatment facility or to a designated collection point for recycling, according to local legislation. The separate collection and recycling of waste electronic equipment at the time of disposal helps to conserve natural resources and ensures that the product is recycled in a manner that protects human health and the environment.



QIAGEN accepts its responsibility in accordance with the specific WEEE recycling requirements and, where a replacement product is being supplied by QIAGEN, provides free recycling of its WEEE-marked electronic equipment in Europe. If a replacement product is not being purchased from QIAGEN, recycling can be provided upon request at additional cost. To recycle electronic equipment, contact your local QIAGEN sales office for the required return form. Once the form is submitted, you will be contacted by QIAGEN either to request follow-up information for scheduling collection of the electronic waste or to provide you with an individual quote.

## **FCC declaration**

The "United States Federal Communications Commission" (USFCC) (in 47 CFR 15.105) declared that the users of this product must be informed of the following facts and circumstances.

"This device complies with part 15 of the FCC:

Operation is subject to the following two conditions: (1) This device may not cause harmful interference, and (2) this device must accept any interference received, including interference that may cause undesired operation."

"This Class A digital apparatus complies with Canadian ICES-0003."

The following statement applies to the products covered in this manual, unless otherwise specified herein. The statement for other products will appear in the accompanying documentation.

**NOTE:** This equipment has been tested and found to comply with the limits for a Class A digital device, pursuant to part 15 of the FCC Rules. These limits are designed to provide reasonable protection against harmful interference when the equipment is operated in a commercial environment. This equipment generates, uses, and can radiate radio frequency energy and, if not installed and used in accordance with the instruction manual, may cause harmful interference to radio communications. Operation of this equipment in a residential area is likely to cause harmful interference in which case the user will be required to correct the interference at his own expense.

QIAGEN GmbH, Germany is not responsible for any radio or television interference caused by unauthorized modifications of this equipment or the substitution or attachment of connection cables and equipment other than those specified by QIAGEN GmbH, Germany. The correction of interference caused by such unauthorized modification, substitution, or attachment will be the responsibility of the user.

## EC declaration of conformity

Name and address of the company

**QIAGEN GmbH  
QIAGEN Strasse 1  
40724 Hilden  
Germany**

We herewith declare that the product

**EZ1 Advanced XL, cat. no. 9001492**

meets all applicable requirements of the following European Directives

<b>Low Voltage Directive (LVD)</b>	<b>2006/95/EC</b>
<b>Electromagnetic Compatibility Directive (EMC)</b>	<b>2004/108/EC</b>
<b>In vitro diagnostic medical devices (IVD)*</b>	<b>98/79/EC</b>

Hombrechtikon, 12 December 2008

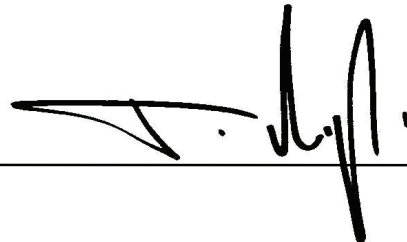

---

**Pit Muggli**

Director Business Excellence

QIAGEN Instruments AG



\* Only in combination with dedicated EZ1 DSP Kits.



## Appendix B

### **Liability clause**

QIAGEN shall be released from all obligations under its warranty in the event repairs or modifications are made by persons other than its own personnel, except in cases where the Company has given its written consent to perform such repairs or modifications.

All materials replaced under this warranty will be warranted only for the duration of the original warranty period, and in no case beyond the original expiration date of original warranty unless authorized in writing by an officer of the Company. Read-out devices, interfacing devices and associated software will be warranted only for the period offered by the original manufacturer of these products. Representations and warranties made by any person, including representatives of QIAGEN, which are inconsistent or in conflict with the conditions in this warranty shall not be binding upon the Company unless produced in writing and approved by an officer of QIAGEN.

## Appendix B

---

This page intentionally left blank

---

# Index

## B

Bar code reader, 5-31  
installing, 4-10

## C

Cartridge rack, 3-9  
Connector panel, 3-5  
Control panel, 3-1, 3-2

## D

Door, 3-1, 3-2  
closing, 5-7  
opening, 5-7

## E

Elution tubes, 3-7  
loading, 5-13  
EZ1 Advanced XL Card, 3-1  
inserting, 5-2  
removing, 5-4  
slot, 3-2, 3-4

## F

Filter-tips, 3-7  
loading, 5-13  
Fuse box, 3-6, 4-2

## G

Glossary, 8-1

## H

Heating positions, 3-10  
Heating system, 3-1, 3-10

## M

Magnet, 3-11  
Magnetic particles, 3-1  
Maintenance, 6-1  
daily, 6-6  
decontamination, 6-9  
weekly, 6-8  
Manual operation, 5-19  
clean, 5-20  
home axis, 5-19  
resend, 5-21  
return tip, 5-20

## O

Operating conditions, 1-4, A-1

## P

PC software, 5-38  
installing, 4-11, 4-16  
user interface, 5-38  
Piercing unit, 3-11  
Pipettor head, 3-1, 3-11  
Power cord, 3-6  
Power requirements, 4-1  
Power switch, 3-6  
Printer, 5-32  
installing, 4-10  
Protocol, 3-1  
starting and finishing, 5-8  
stopping, 5-9

## R

Racks, 3-6  
Reagent cartridges, 3-1, 3-9  
loading, 5-11  
Reagent wells, 3-10  
Report file, 5-34

## Index

---

### S

#### Safety

- biological, 1-4
- chemical, 1-6
- electrical, 1-3
- heat hazard, 1-7
- mechanical hazards, 1-7
- proper use, 1-2
- symbols, 1-8

#### Sample tubes, 3-7

- loading, 5-13

#### Servicing, 6-3

#### Status LEDs, 3-2, 3-5

#### Storage conditions, A-2

#### Switching off, 5-6

#### Switching on, 5-5

#### Symbols, 1-8, 1-9

#### Syringe pumps, 3-11

#### System setup, 5-28

- date, 5-28
- preventive maintenance reminder,  
5-31
- serial port, 5-30
- time, 5-29

### T

#### Test, 5-22

- axis, 5-23

#### heating block, 5-24

#### serial port, 5-25

#### version, 5-28

#### Tip adapters, 3-11

#### Tip holders, 3-1, 3-7

#### Tip rack, 3-7

#### Tips, 3-7

#### loading, 5-13

#### Transportation conditions, A-2

#### Tray, 3-10

#### removing, 5-11

#### Troubleshooting, 7-1

#### door, 7-1

#### error codes, 7-3

### U

#### UV lamp, 3-12, 5-15, 5-18

#### switching off, 5-17

#### switching on, 5-16

### V

#### VFD, 3-2, 3-3

### W

#### Waste disposal, 1-6, A-6

#### Worktable, 3-1, 3-6

#### setting up, 5-10



[www.qiagen.com](http://www.qiagen.com)

**Australia** ■ Orders 03-9840-9800 ■ Fax 03-9840-9888 ■ Technical 1-800-243-066

**Austria** ■ Orders 0800/28-10-10 ■ Fax 0800/28-10-19 ■ Technical 0800/28-10-11

**Belgium** ■ Orders 0800-79612 ■ Fax 0800-79611 ■ Technical 0800-79556

**Brazil** ■ Orders 0800-557779 ■ Fax 55-11-5079-4001 ■ Technical 0800-557779

**Canada** ■ Orders 800-572-9613 ■ Fax 800-713-5951 ■ Technical 800-DNA-PREP (800-362-7737)

**China** ■ Orders 0086-21-3865-3865 ■ Fax 0086-21-3865-3965 ■ Technical 800-988-0325, 800-988-0327

**Denmark** ■ Orders 80-885945 ■ Fax 80-885944 ■ Technical 80-885942

**Finland** ■ Orders 0800-914416 ■ Fax 0800-914415 ■ Technical 0800-914413

**France** ■ Orders 01-60-920-926 ■ Fax 01-60-920-925 ■ Technical 01-60-920-930 ■ Offers 01-60-920-928

**Germany** ■ Orders 02103-29-12000 ■ Fax 02103-29-22000 ■ Technical 02103-29-12400

**Hong Kong** ■ Orders 800 933 965 ■ Fax 800 930 439 ■ Technical 800 930 425

**Ireland** ■ Orders 1800 555 049 ■ Fax 1800 555 048 ■ Technical 1800 555 061

**Italy** ■ Orders 02-33430-420 ■ Fax 02-33430-426 ■ Technical 800-787980

**Japan** ■ Telephone 03-6890-7300 ■ Fax 03-5547-0818 ■ Technical 03-6890-7300

**Korea (South)** ■ Orders 1544 7145 ■ Fax 1544 7146 ■ Technical 1544 7145

**Luxembourg** ■ Orders 8002-2076 ■ Fax 8002-2073 ■ Technical 8002-2067

**Mexico** ■ Orders 01-800-7742-639 ■ Fax 01-800-1122-330 ■ Technical 01-800-7742-639

**The Netherlands** ■ Orders 0800-0229592 ■ Fax 0800-0229593 ■ Technical 0800-0229602

**Norway** ■ Orders 800-18859 ■ Fax 800-18817 ■ Technical 800-18712

**Singapore** ■ Orders 65-67775366 ■ Fax 65-67785177 ■ Technical 65-67775366

**Spain** ■ Orders 91-630-7050 ■ Fax 91-630-5145 ■ Technical 91-630-7050

**Sweden** ■ Orders 020-790282 ■ Fax 020-790582 ■ Technical 020-798328

**Switzerland** ■ Orders 055-254-22-11 ■ Fax 055-254-22-13 ■ Technical 055-254-22-12

**UK** ■ Orders 01293-422-911 ■ Fax 01293-422-922 ■ Technical 01293-422-999

**USA** ■ Orders 800-426-8157 ■ Fax 800-718-2056 ■ Technical 800-DNA-PREP (800-362-7737)

